







Index

- 196 Angel Falls
- 124 Anish
- 102 Argent
- 014 Atlantis
- 224 Bond
- 134 Calle
- 188 Core
- 082 Doodle
- 008 Epoque
- 144 Etoile
- 152 Frame
- 210 Glamour
- 180 G.r.a
- 242 Hook
- 250 Hugo
- 206 Iceberg
- 112 I Lucci Argentati
- 064 Kika
- 218 Magdalena
- 054 Manta
- 070 Mizu
- 162 Orten'zia
- 228 Sea Urchin
- 202 Shar Pei
- 028 Soscik
- 034 Stream
- 236 Tresor
- 044 Volver
- 254 Wabi
- 246 Zig-Zag

Terzani's Precious Design Concept is luxury evolved. Each piece in this new lighting collection breaks the staid boundaries of traditional luxury, and incorporates stunningly modern design, cutting-edge technology, artisan craftsmanship and precious materials. The result are sculptures of light whose illumination transforms spaces through dynamic lighting and shadow effects. They create a new visual language of what luxury is, one that reflects both today's aesthetics, architecture and design traditions yet also pushes towards the future.



Precious Design

Epoque, Cyclical *Light.*

Epoque is a light sculpture designed to study chiaroscuro and volumes. The result is a modern expression of these Renaissance-era techniques in a stunning chandelier. Composed of curved, organic lines, Epoque's frame is made of flexible and durable brass metal, suspended by nickel metal chains. Two bands of metal, a central elongated section and an external band of wide arcs, allows the light to envelop a room in reflections of soft light. Epoque has attracted attention from those in the design community with discerning tastes. Epoque is available in nickel, black nickel and gold finish. Design Stefano Papi & Saviz Yaghmai.





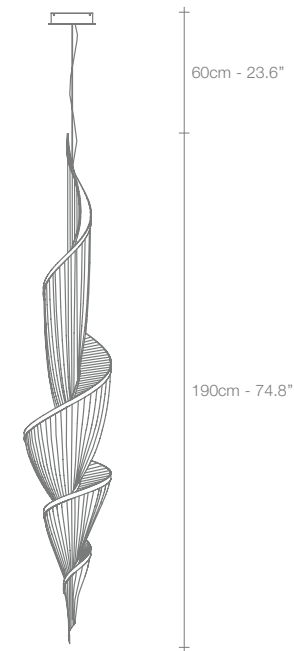

60cm - 23.6"

190cm - 74.8"

Ø35cm - 13.8"

G91S

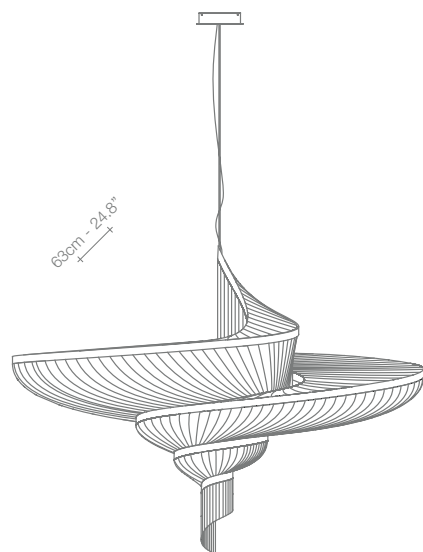

63cm - 24.8"

90cm - 35.4"

100cm - 39.4"

136cm - 53.5"

G90S



NICKEL



*BLACK NICKEL



*BRONZE



*GOLD

G90S G91S

230V



LED integrated 18X2.5W 10X2.5W

120V



LED integrated 18X2.5W 10X2.5W



* These finishes are available only for G91S

Atlantis, a Precious *Wave.*

Seemingly alive, Atlantis shimmering light creates a vibrant source of energy. Its mesmerizing, organic effect is created by hundreds of illuminated lengths of draped, nickel chain. Like water in the ocean, Atlantis chains appear liquid, cascading over its gloss nickel bands and falling down towards the abyss before turning back into itself. Atlantis is composed of almost three miles of chain, meticulously hand-crafted by master Italian artisans. Design Barlas Baylar.













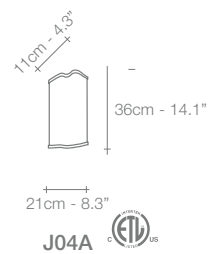
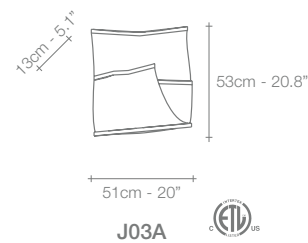
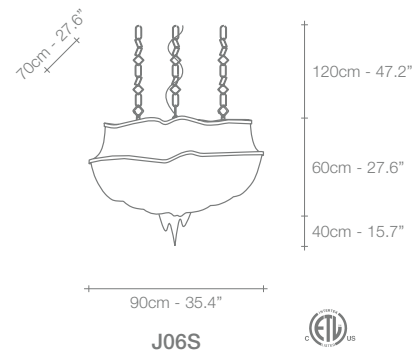
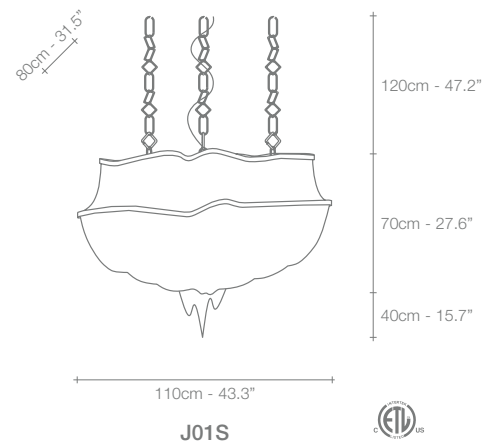
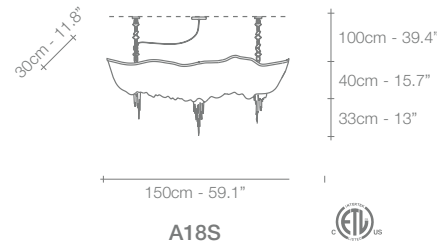
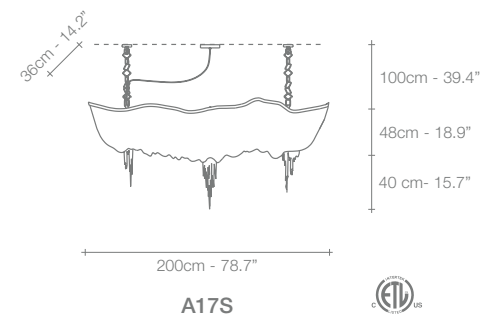
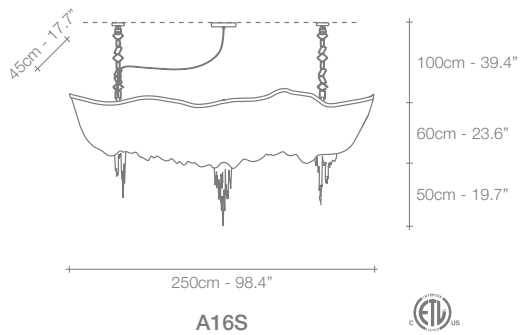
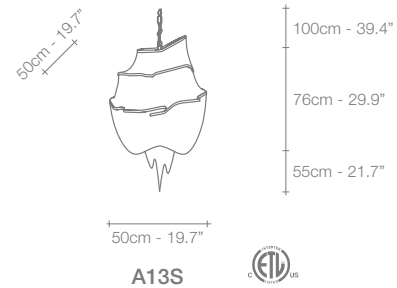
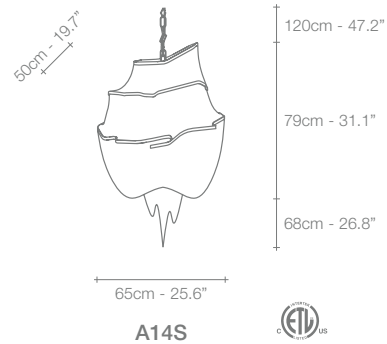
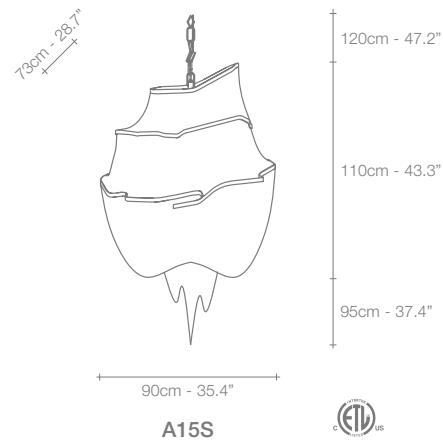

NICKEL



BLACK NICKEL



BRONZE



GOLD

	A13S	A14S	A15S	A16S	A17S	A18S	J01S	J03A	J04A	J06S
230V	HALOGEN ES E14	6X42W (=6x60W)	8X42W (=8x60W)	8X42W (=8x60W)	10X42W (=10x60W)	10X42W (=10x60W)	8X42W (=8x60W)	4X28W (=4x40W)	2X42W (=2x60W)	8X42W (=8x60W)
120V	FLAME CA 10 E12	6X60W	8X60W	8X60W	10X60W	10X60W	8X60W	4X40W	2X60W	8X60W

LED LIGHT BULBS MAY BE USED



Soscik, Classic form, *Modern look.*

Reinventing the classics. With Soscik, Terzani combines traditional, artisan techniques with cutting edge technology to give the traditional chandelier a modern update. Over the plated frame, Soscik creates a dramatic and romantic effect, while still being able to compliment today's modern luxury. Available as a chandelier or a ceiling lamp, Soscik proves that modern design does not have to sacrifice luxury. Design Nicolas Terzani.





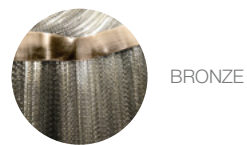
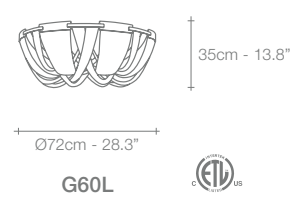
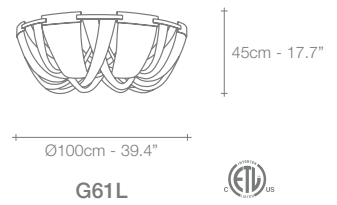
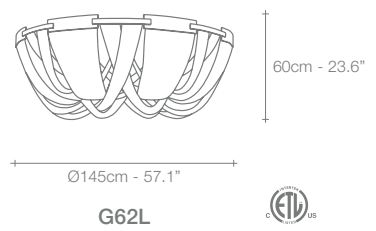
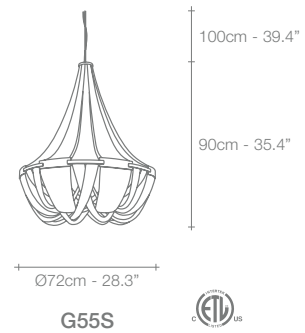
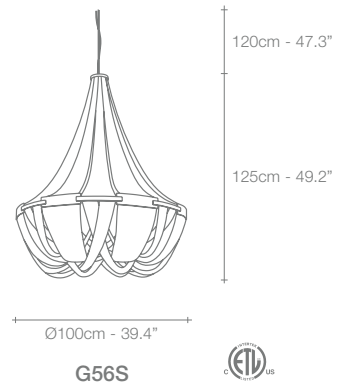
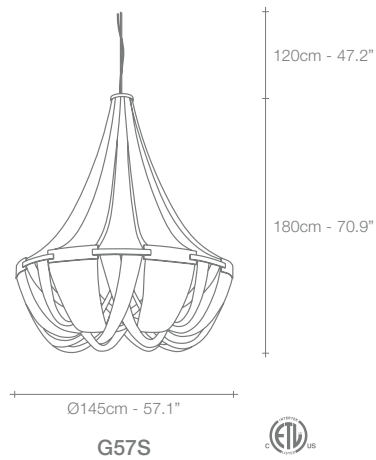

	G55S	G56S	G57S	G60L	G61L	G62L
230V	HALOGEN ES G9	8X33W (=8X40W)	12X33W (=12X40W)	14X33W (=14X40W)	8X33W (=8X40W)	10X33W (=10X40W)
120V	HALOGEN JCD G9	8X35W	12X35W	14X35W	8X35W	10X35W

LED LIGHT BULBS MAY BE USED



Stream, Iridescent *Light.*

A stunning design from Christian Lava, Stream is an impressive presence in any room. Stream's design exploits the physical characteristics of the materials used to envelop a room in a unique, immersive light. Here, an elegant thin metal chain appear to flow down from the undulating, nickel-plated frame. These cascading tiers project a streaking, yet tranquil, shadow throughout the room. Design Christian Lava.









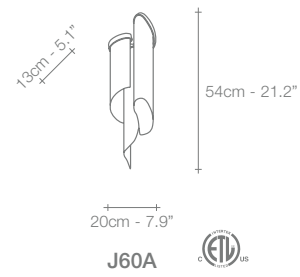
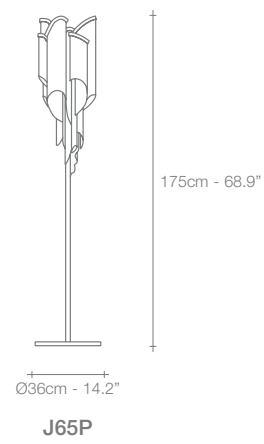
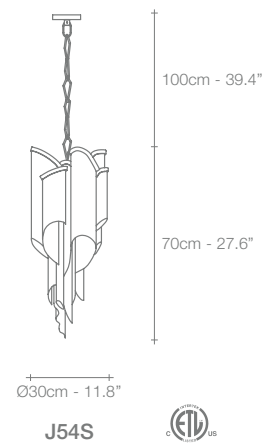
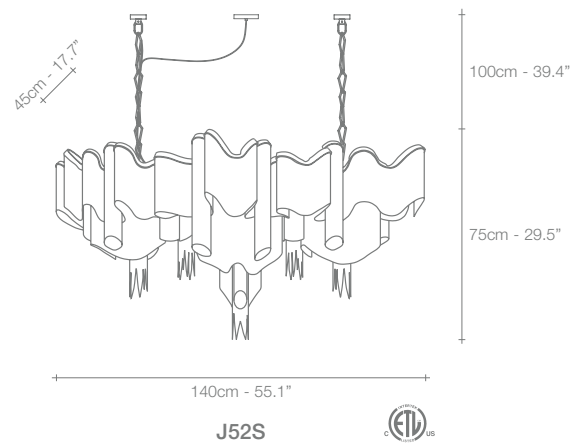
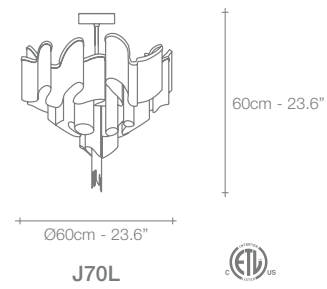
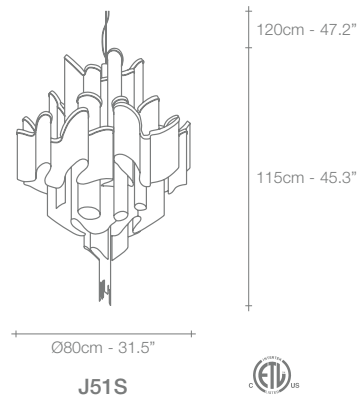
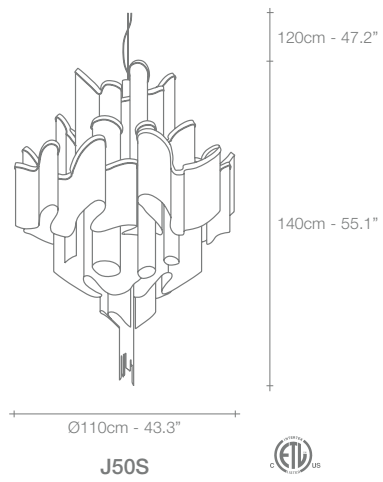

	J50S	J51S	J52S	J70L	J54S	J60A	J65P			
230V	LED E14 + LED GU10	20X4W E14 + 4W GU10	18X4W E14 + 4W GU10	LED G9 + LED GU10	12X3.5W G9 + 3X4W GU10	8X3.5W G9 + 4W GU10	4X3.5W G9 + 4W GU10	LED E14	2X6W	6X4W
120V	LED E12 + LED MR20 GU10	20X5W E12 + 4W GU10	18X5W E12 + 4W GU10	LED G9 + LED MR20 GU10	12X3.5W G9 + 3X4W GU10	8X3.5W G9 + 4W GU10	4X3.5W G9 + 4W GU10	LED E12	2X7W	6X5W



Volver, Breath of new *Light.*

At Terzani, we are fortunate to work with some of the brightest young stars in Italian design. For Volver, designer Diego Bassetti and architect Andrea Panzieri of Studio 14, protégés of Bruno Rainaldi, applied their multidisciplinary approach to create Terzani's first LED suspension light. This geometric design combines thin nickel chains with the latest in LED technology to create a light that is both elegant and modern. A breath of new light, Volver melds technology and art to achieve a new level of luxury. Design Studio 14.







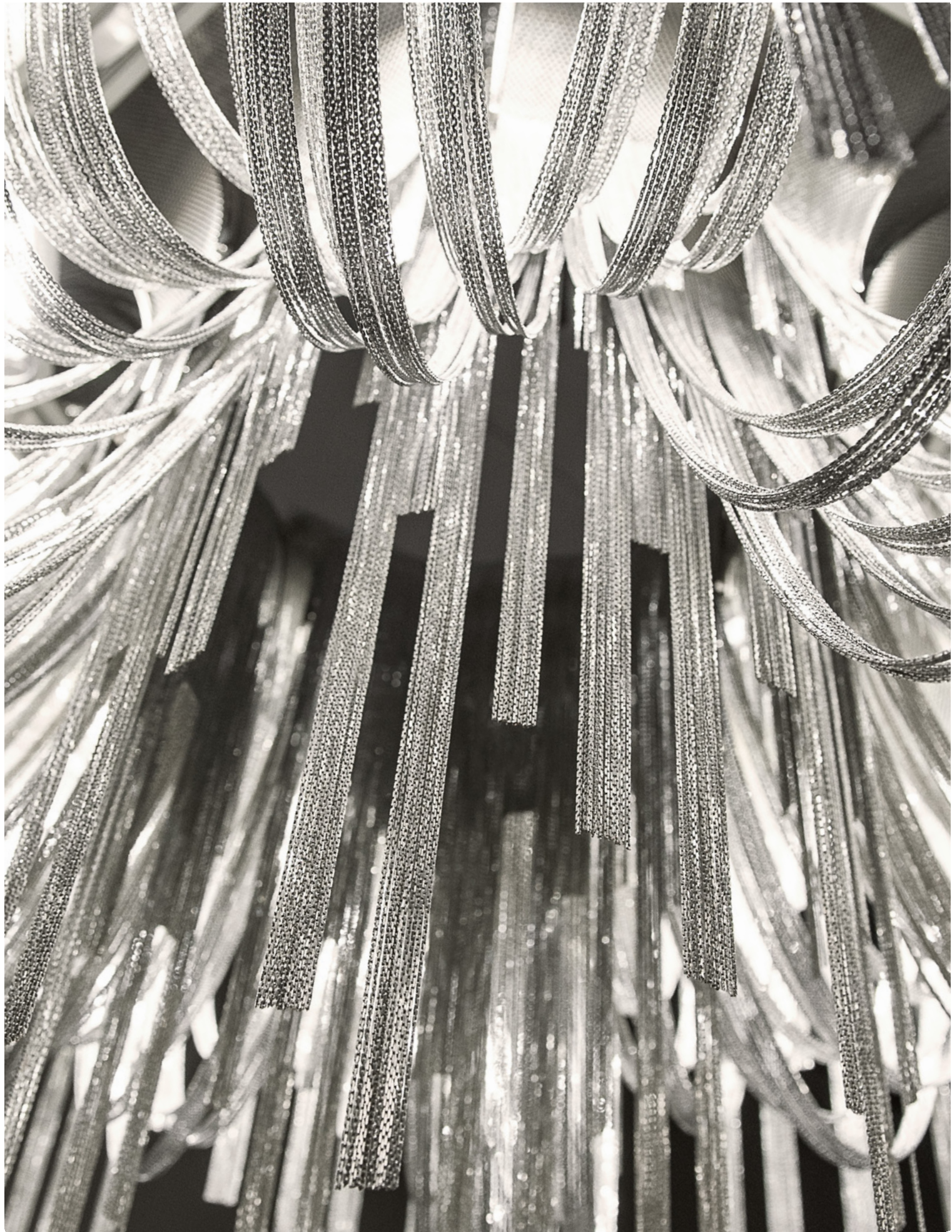

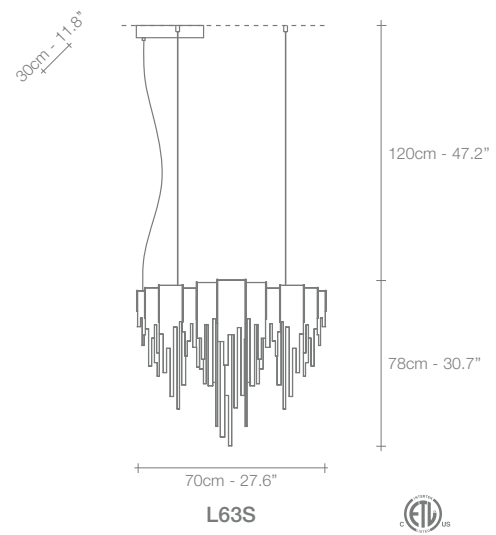
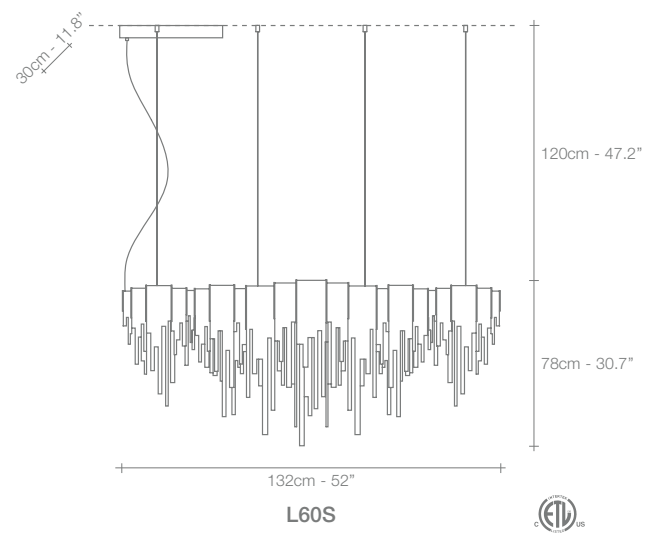
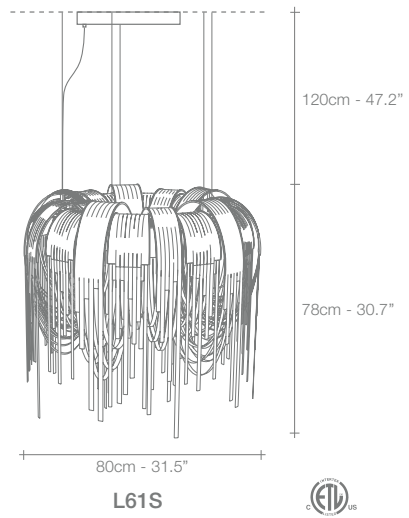
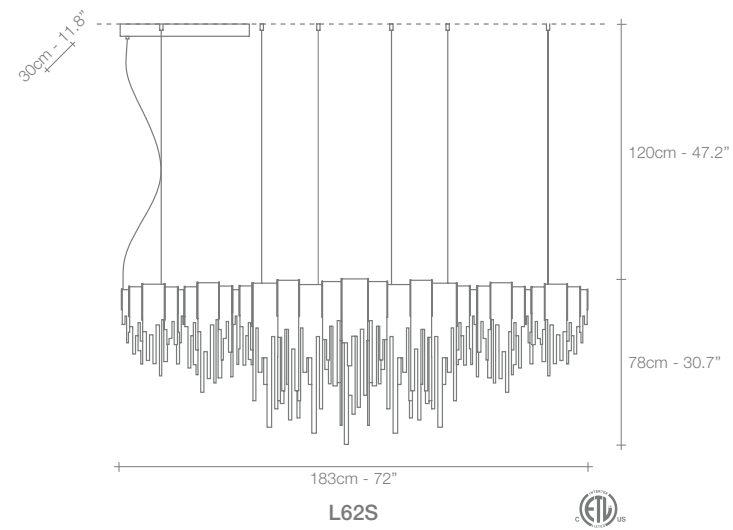

NICKEL



BLACK NICKEL



GOLD



BRONZE

230V / 120V

LED BOARD
3000 K
CRI 90

L60S	L61S	L62S	L63S
10X4.5W	10X4.5W	20X4.5W	7X4.5W

2700K - CRI 90
LED BOARD
AVAILABLE ON
REQUEST

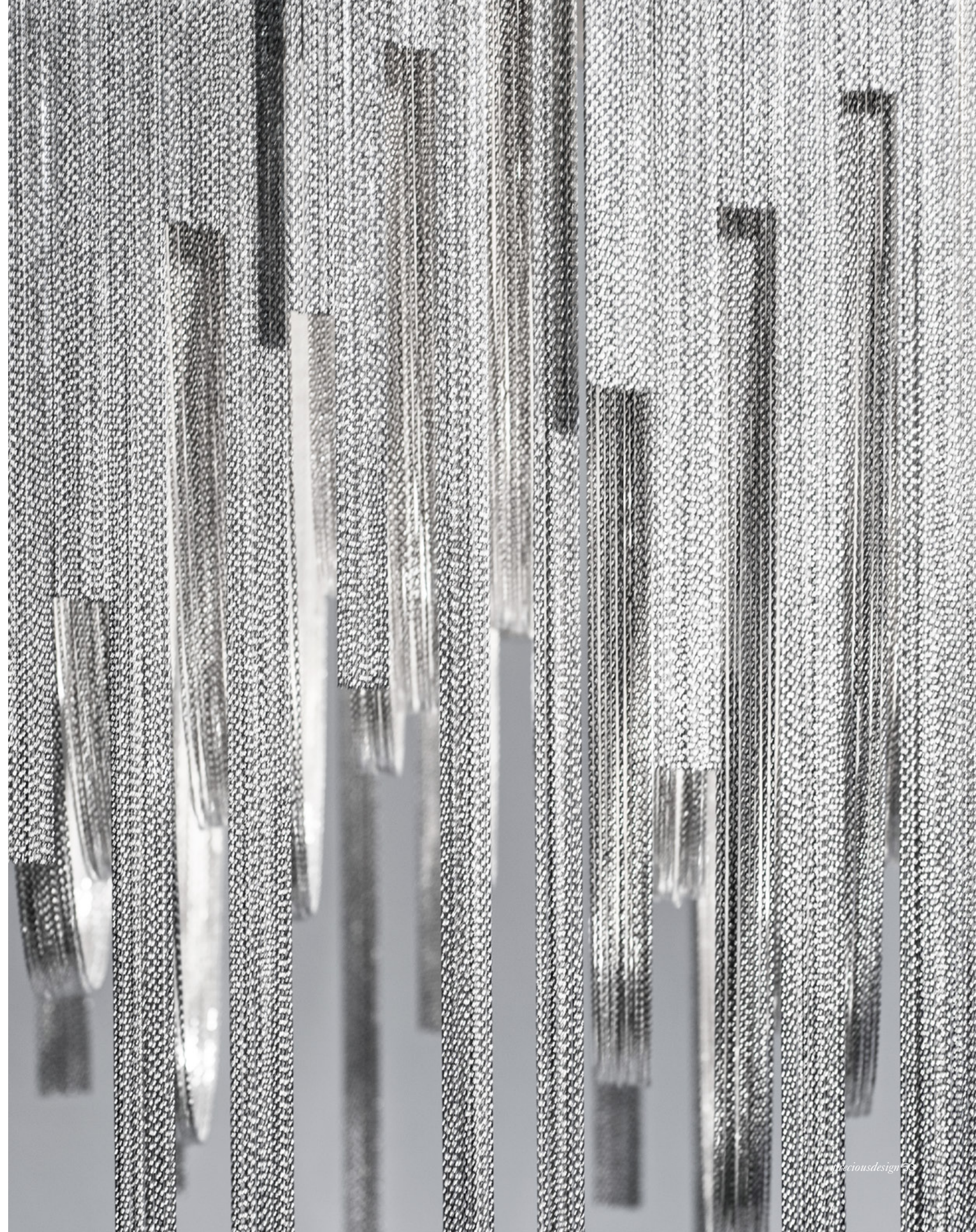

Manta, Shimmering *Waves.*

Manta is the latest design featuring the distinctive crystal first unveiled in Nicolas Terzani's best-selling Mizu. Collaborating with designer Dodo Arslan, the two imaginative minds created a light featuring sinuous, undulating lines. The results are soft waves of crystal light reminiscent of being underwater. The innovative Manta is made of crystal, with a dimmable integrated LED lamp focused on maximizing the crystal's reflection. Manta's organic form is available in three sizes (Ø 20cm-7.9", Ø 26cm-10.2", Ø 32cm-12.6") and can be installed in numerous, customizable arrangements. Design Dodo Arslan & Nicolas Terzani.









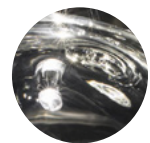
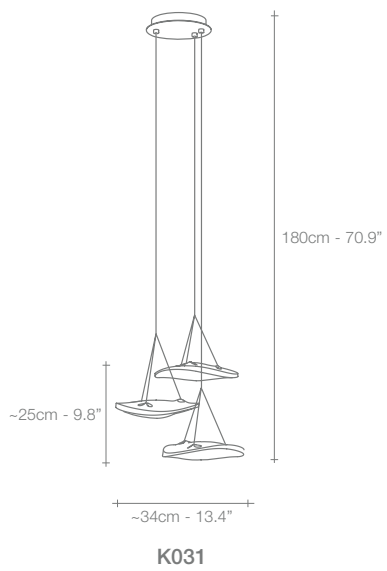
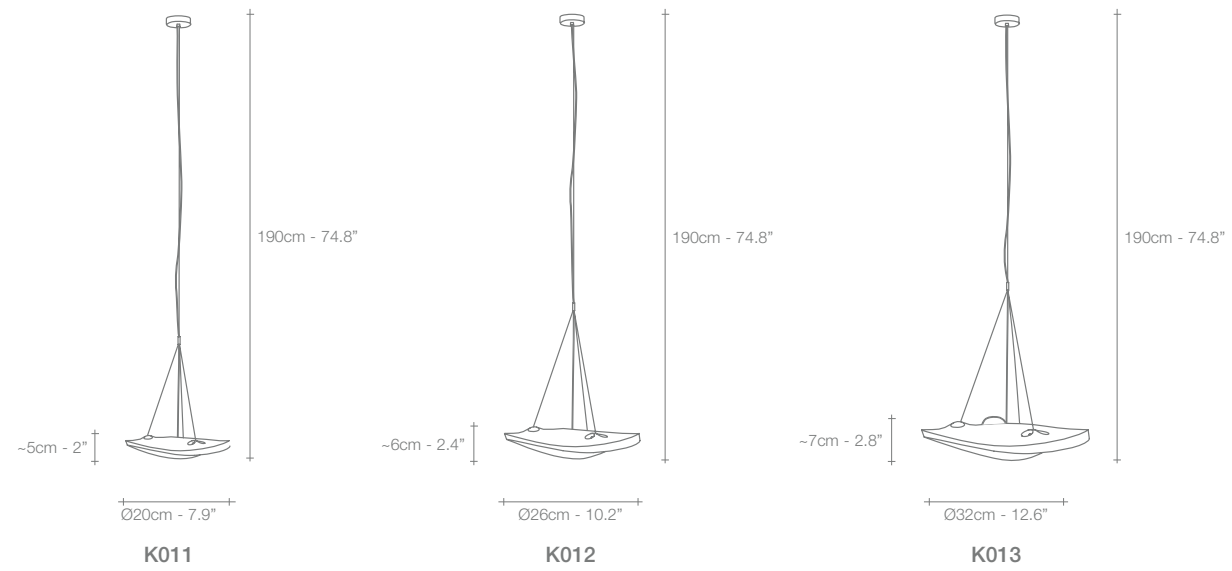

CLEAR CRYSTAL

	K011	K012	K013	K031
230V	LED integrated	1.5W	1.5W	2X1.5W 3X1.5W
120V	LED integrated	1.5W	1.5W	2X1.5W 3X1.5W



Kika, Get *Dressed Up.*

The glamour and allure of the Golden Age of Hollywood drove the inspiration for Terzani's newest pendant, Kika. Incorporating modern technology with new materials, designer Franziska Hinze created a contemporary fixture reflecting this exciting period in cinema. Balancing proportions was also part of the inspiration behind Kika's shape. The light is made of hundreds of photo-etched metal pendants, attached meticulously by hand to metal rings. The final result is similar to that of a fine jewel, floating in the air, and shining in every direction. To enhance the contrast of light, Terzani offers Kika in different color and size variations. Kika is a unique piece that adds vibrancy with a shimmering, suspended light. Design Franziska Hinze.





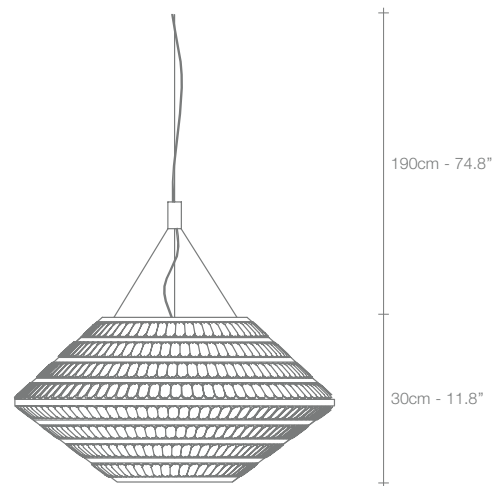

190cm - 74.8"

30cm - 11.8"

Ø67cm - 26.4"

Q20S

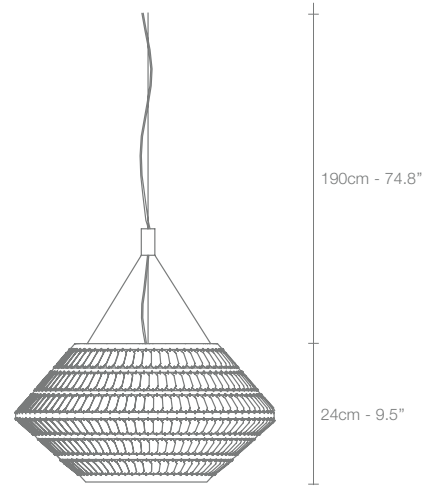

190cm - 74.8"

24cm - 9.5"

Ø54cm - 21.3"

Q21S

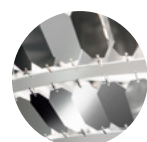

WHITE
STAINLESS STEEL

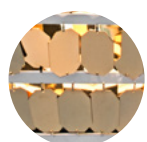

WHITE
GOLD

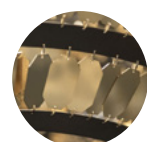

BLACK
GOLD



230V

LED
E27 globe 8W 8W



120V

LED
E26 globe 8W 8W

Q20S Q21S



Mizu, Flowing *Light.*

Inspired by the tranquil and mesmerizing light refractions created by water, Mizu is customizable pendant light from Terzani. Like water droplets, no two Mizu are alike, each crystal shape is unique and made meticulously by hand. Using only the clearest crystal, Mizu perfectly emulates water's refraction of light, casing amazing patterns around the room, reminiscent of flowing water. Also available in gold leaf and silver dust. Design Nicolas Terzani.





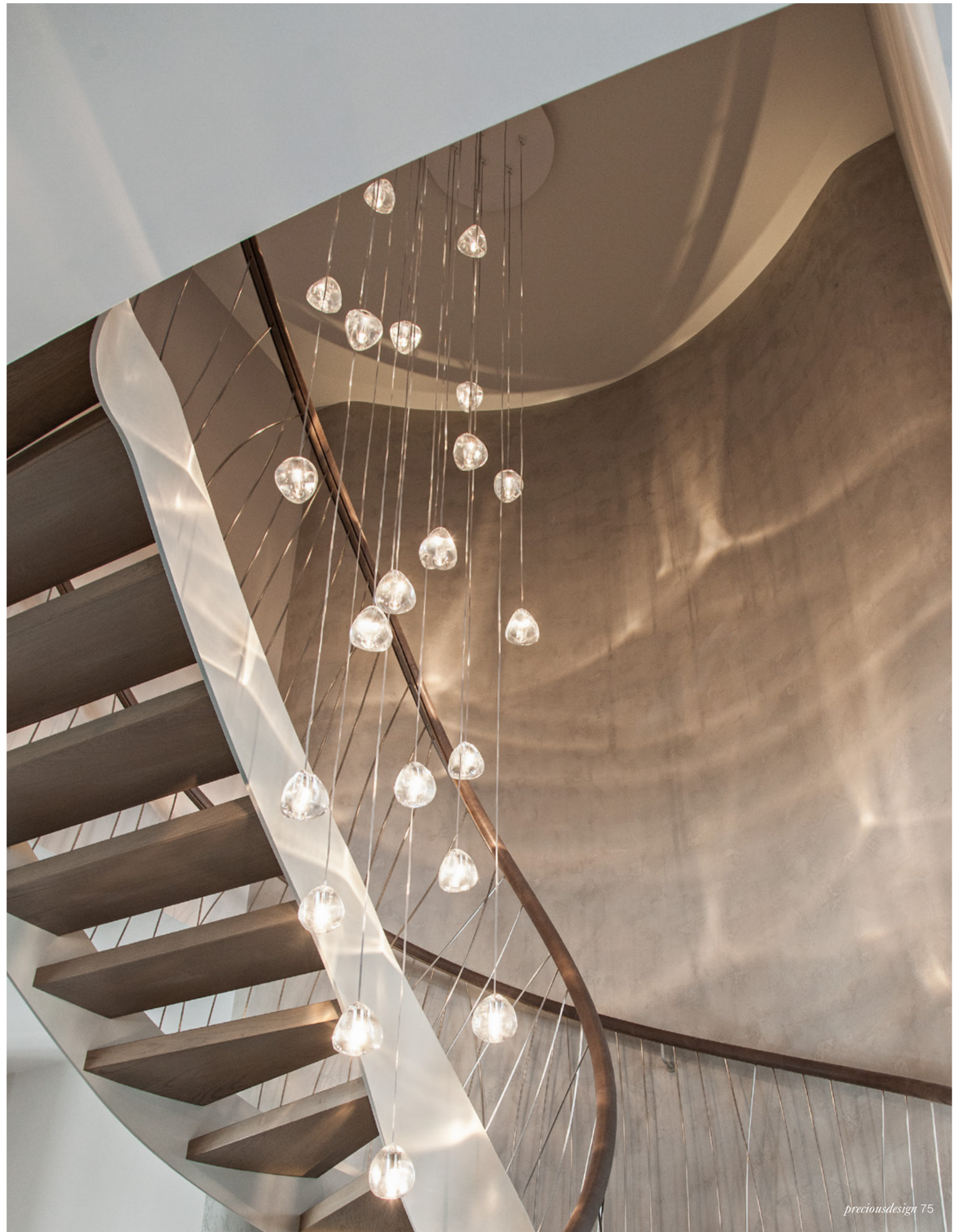





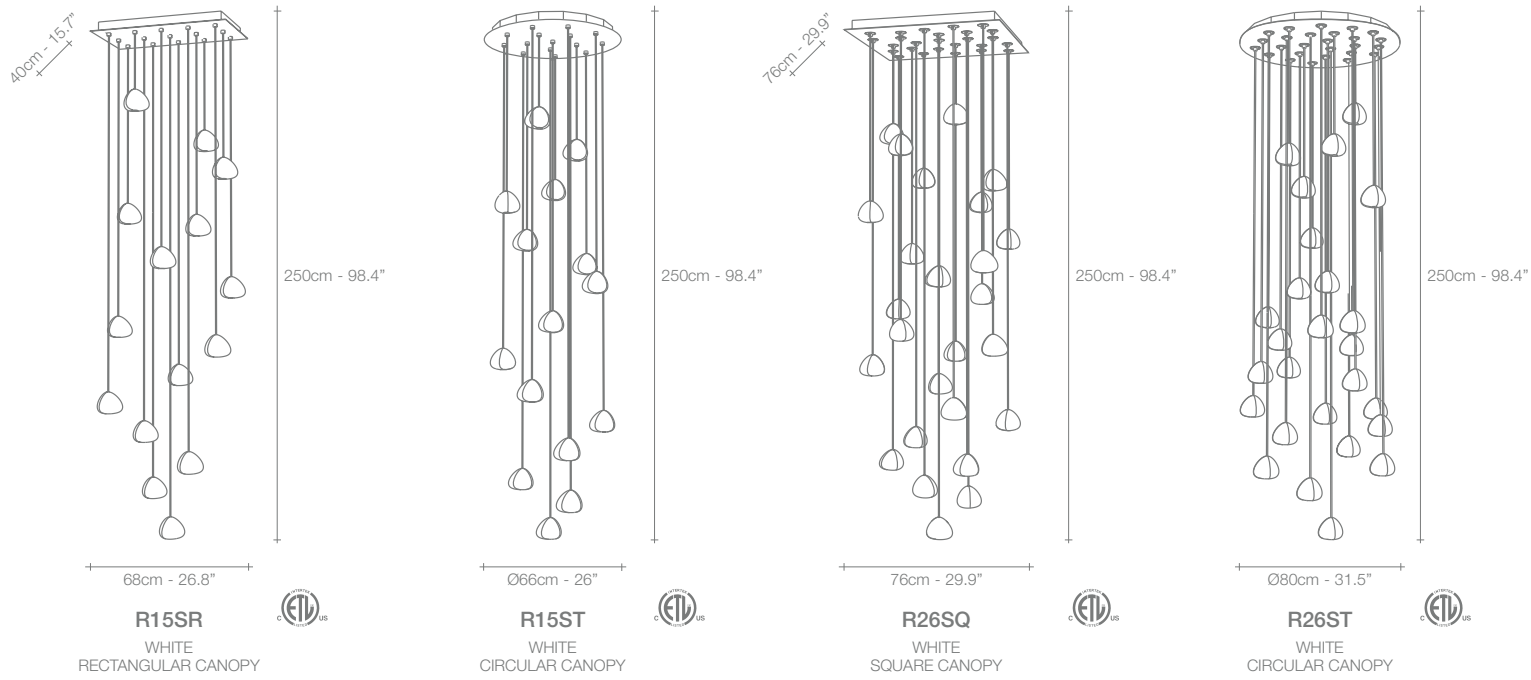
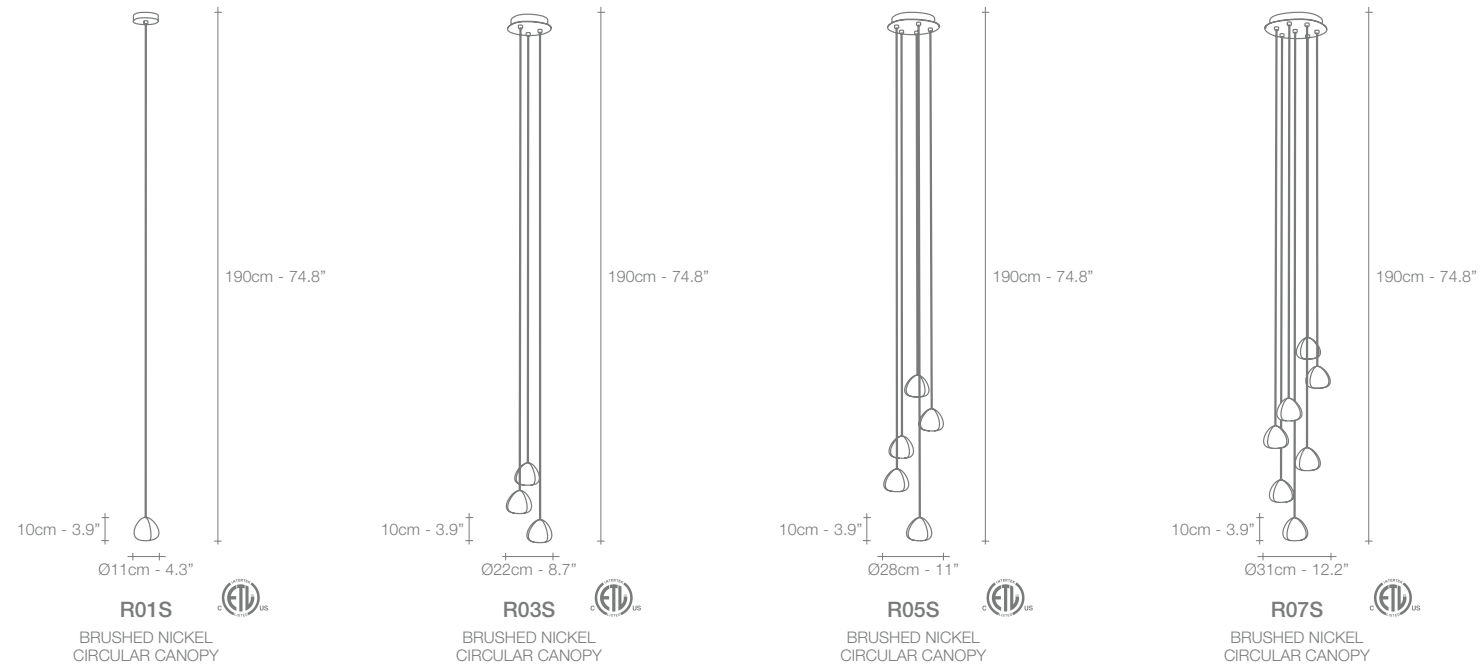

CRYSTAL



GOLD CRYSTAL

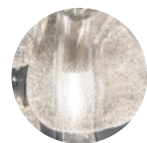

SILVER DUST CRYSTAL

	R01S	R03S	R05S	R07S	R15SR	R15ST	R26SQ	R26ST
230V HALOGEN 12V G4	10W	3X10W	5X10W	7X10W	15X10W	15X10W	26X10W	26X10W
120V XENON BI-PIN 12V T3 G4	10W	3X10W	5X10W	7X10W	15X10W	15X10W	26X10W	26X10W

MIZU CAN BE
MANUFACTURED TO WORK
WITH BI-PIN LED LIGHT
SOURCE ON REQUEST



Doodle, Freehand *Design.*

We no longer march in a straight line. Our lives are dynamic, intertwining collections of relationships, experiences and journeys. Reflecting the fluidity of our generation, designer Simone Micheli has created a new, contemporary light for Terzani, Doodle. Like us, each Doodle is unique, each pendant is handcrafted by artisans to resemble a randomised path. And, to give us control over the journey we want to take, each LED bulb can be placed anywhere on the light, not only reflecting the choices we make in life, but giving Doodle a special flexibility. Design Simone Micheli.



















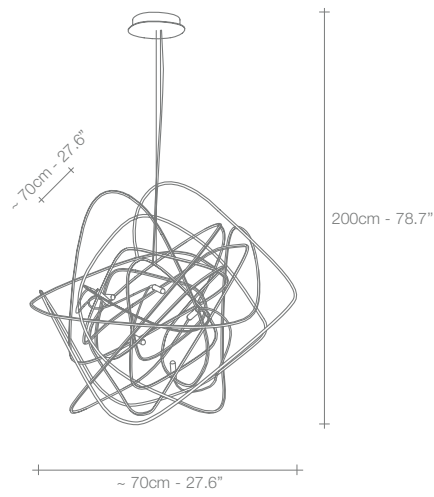

J92S

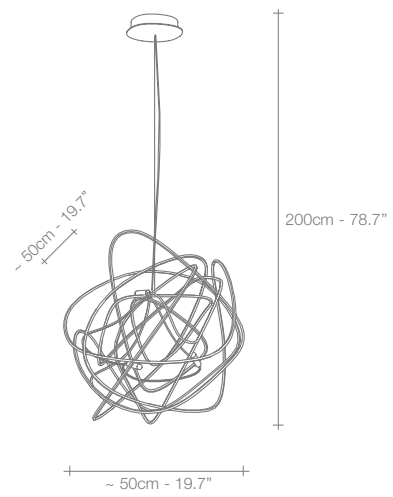

J93S

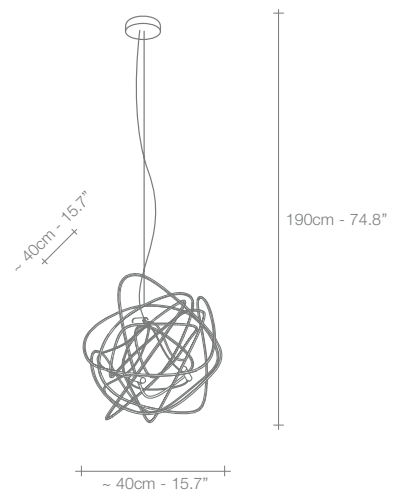

J95S

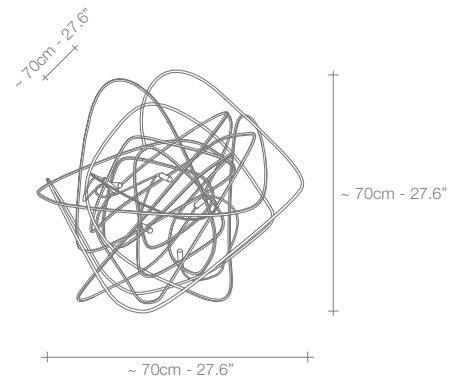

J90P

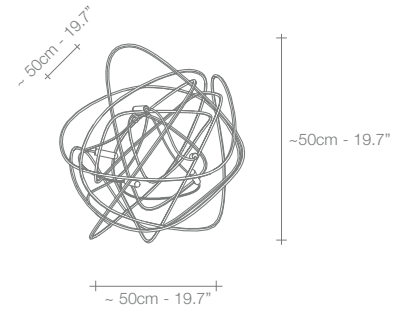

J89P

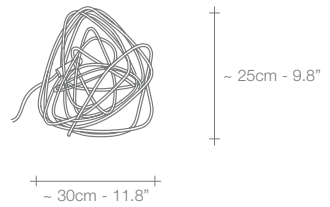

J84B

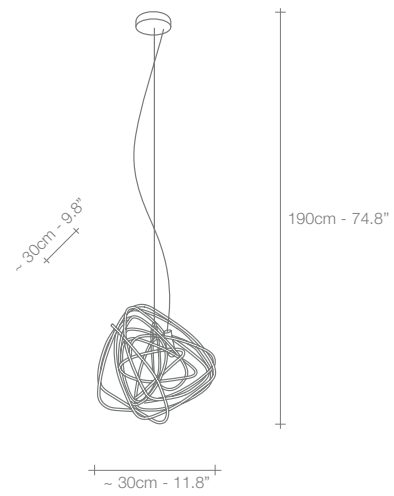

J80S

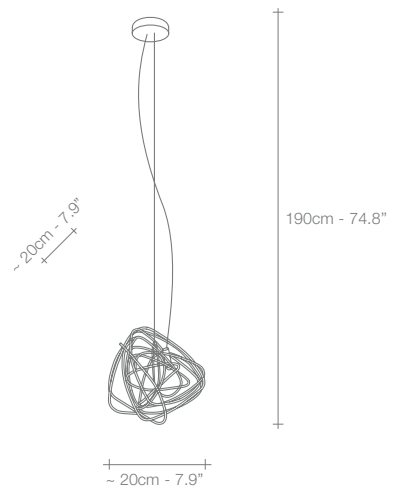

J96S

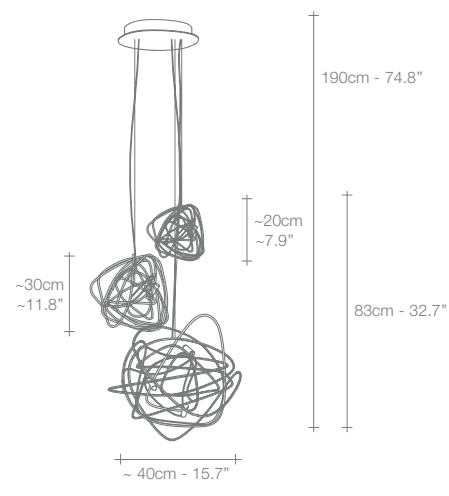

J94S

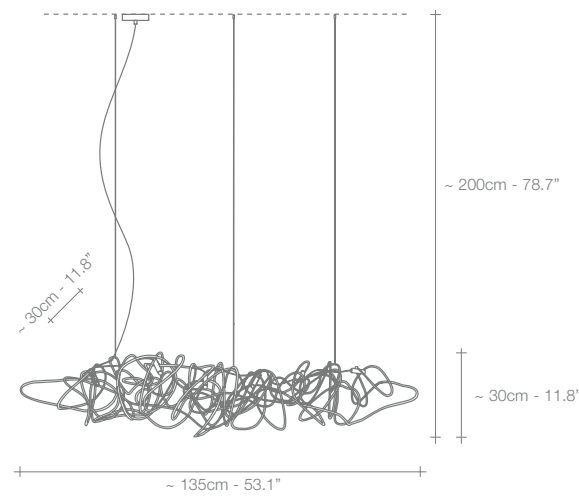

J81S

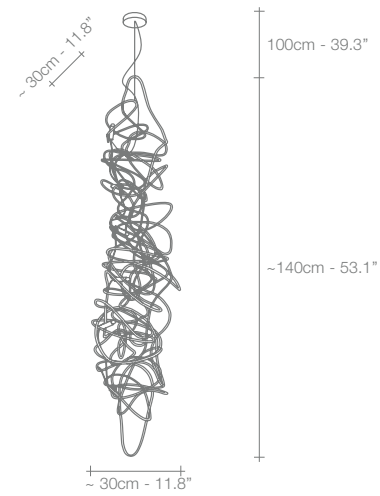

J87S

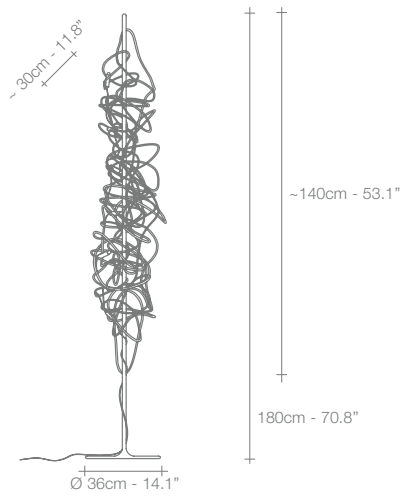

J86P

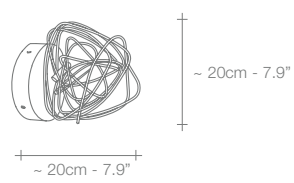

J88A

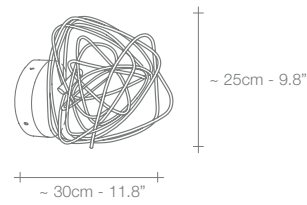

J82A



NICKEL

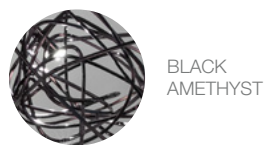

BLACK AMETHYST



GOLD



COPPER

J80S J81S J82A J84B J86P J87S J88A J89P J90P J92S J93S J94S J95S J96S

120V 230V



LED PHILIPS G4 CAPSULE LINE

2W G4 (=20W)	6x2W G4 (=20W)	2W G4 (=20W)	2W G4 (=20W)	6x1.2W G4 (=12W)	6x2W G4 (=20W)	2W G4 (=20W)	5x2W G4 (=20W)	7x1.2W G4 (=12W)	7x2W G4 (=20W)	5x2W G4 (=20W)	5x2W G4 (=20W)	3x2W G4 (=20W)	2W G4 (=20W)
2W G4 (=20W)	6x2W G4 (=20W)	2W G4 (=20W)	2W G4 (=20W)	6x1W G4 (=10W)	2W G4 (=20W)	2W G4 (=20W)	5x2W G4 (=20W)	7x1W G4 (=10W)	7x2W G4 (=20W)	5x2W G4 (=20W)	5x2W G4 (=20W)	3x2W G4 (=20W)	2W G4 (=20W)

Argent, a Silver *Cloud.*

With this suspension light, designer Dodo Arslan creates a shimmering, silver cloud. Argent consists of metal discs that have been meticulously joined by hand by Terzani craftsmen into clusters. Once lit, the multiple, angled surfaces of the discs emanate a soft, shimmering, white glow. Design Dodo Arslan.









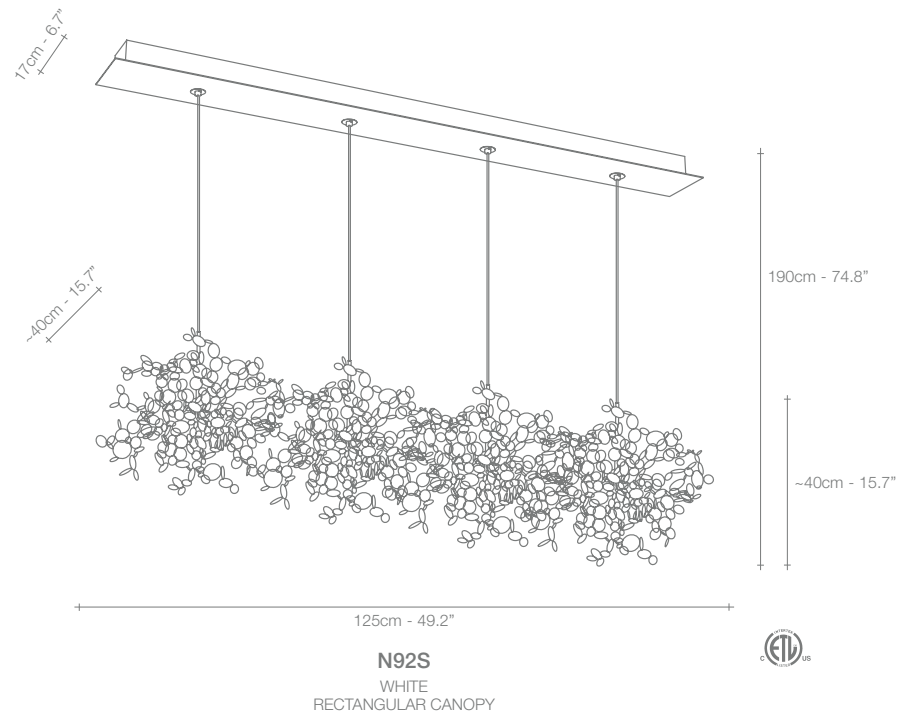
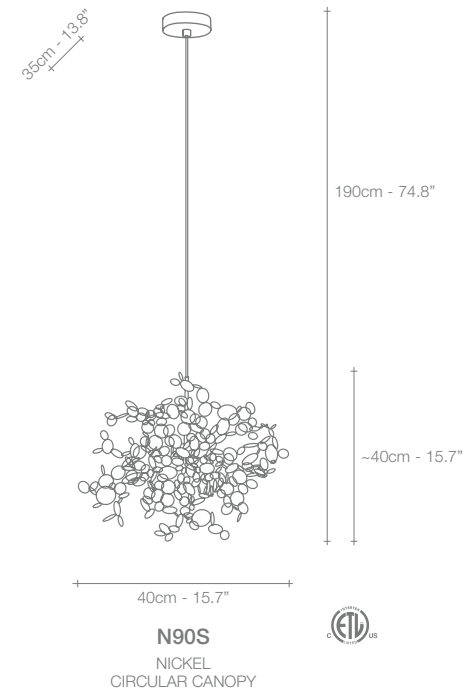
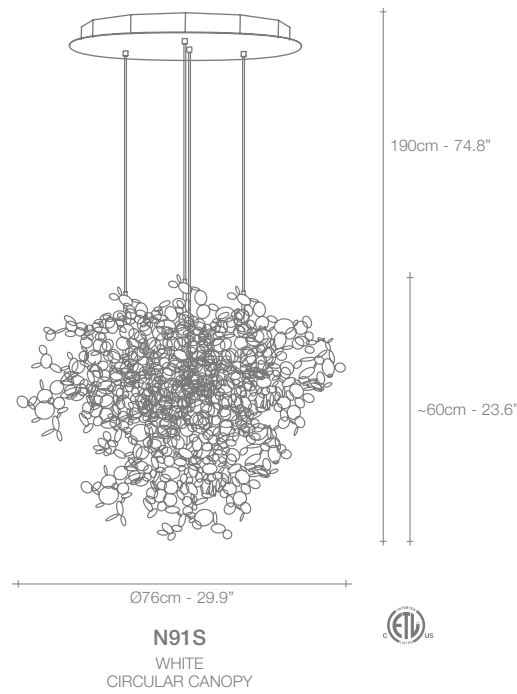

STAINLESS STEEL

	N90S	N91S	N92S
230V	HALOGEN 12V G4	3X20W	12X20W
120V	XENON BI-PIN 12V T3 G4	3X20W	12X20W

ARGENT CAN BE
MANUFACTURED TO WORK
WITH BI-PIN LED LIGHT
SOURCE ON REQUEST



I Lucci Argentati, School of *Light.*

I Lucci Argentati draws from nature to create a whimsical, yet modern light. Recalling a school of fish darting through freshwater, it creates a mesmerizing luminescence. Sets of sleek lights combine to form a stunning pendant with thin incisions along the bottom creating an understated, tranquil beauty. Thanks to its modular system, I Lucci Argentati is customizable and can be combined in many different configurations: from small to extra large; as a pendant or sconce; and finished either in brushed nickel or white. Design Dodo Arslan.











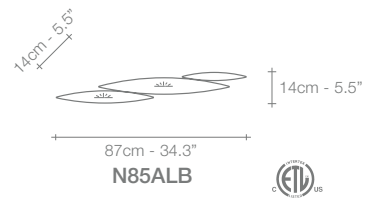
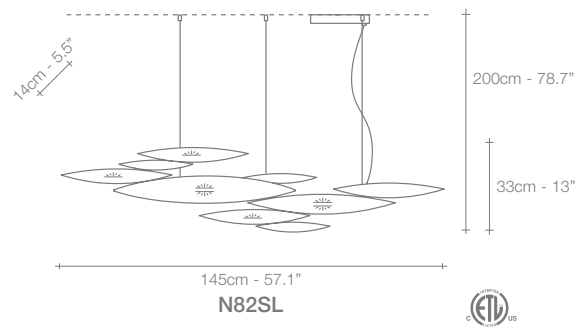
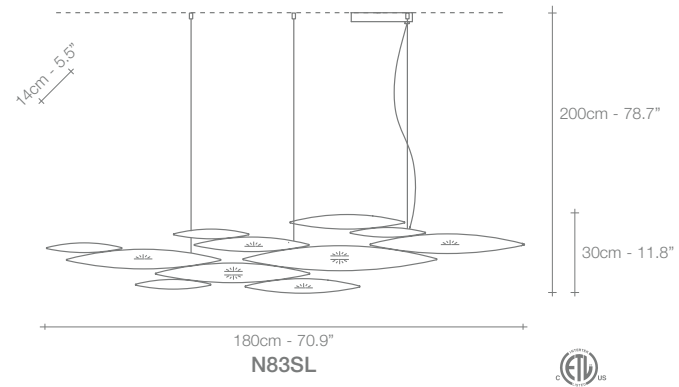
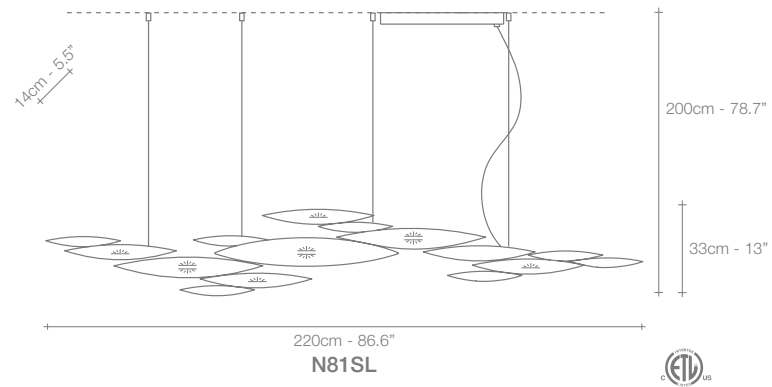
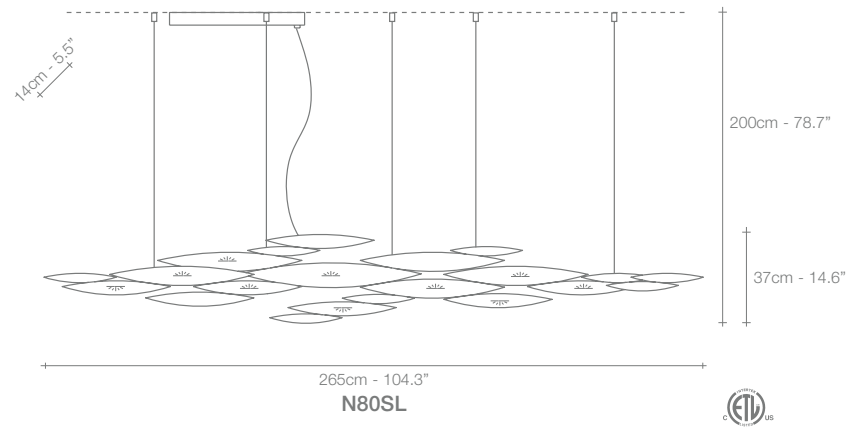

BRUSHED
NICKEL



WHITE

230V / 120V

	N80SL	N81SL	N82SL	N83SL	N85ALB
LED BOARD					
3000 K					
CRI 90	10X4.5W	10X4.5W	7X4.5W	8X4.5W	2X4.5W

2700K - CRI 90
LED BOARD
AVAILABLE ON
REQUEST



Anish, Playing *Spoons.*

A playful study of reflection, the idea for Anish was born when designer Dodo Arslan, while playing with his daughter, became fascinated by the almost infinite reflections spoons unleashed due to their concave and convex surfaces. Taking this idea to a larger scale, Dodo took inspiration from Italian flatware manufacturer and created a pendant composed of a range of spoons from the smallest teaspoon to serving spoons which magnifies the reflective quality of this shape. The result is an installation that creates a “galaxy” effect of seemingly endless light. Design Dodo Arslan.









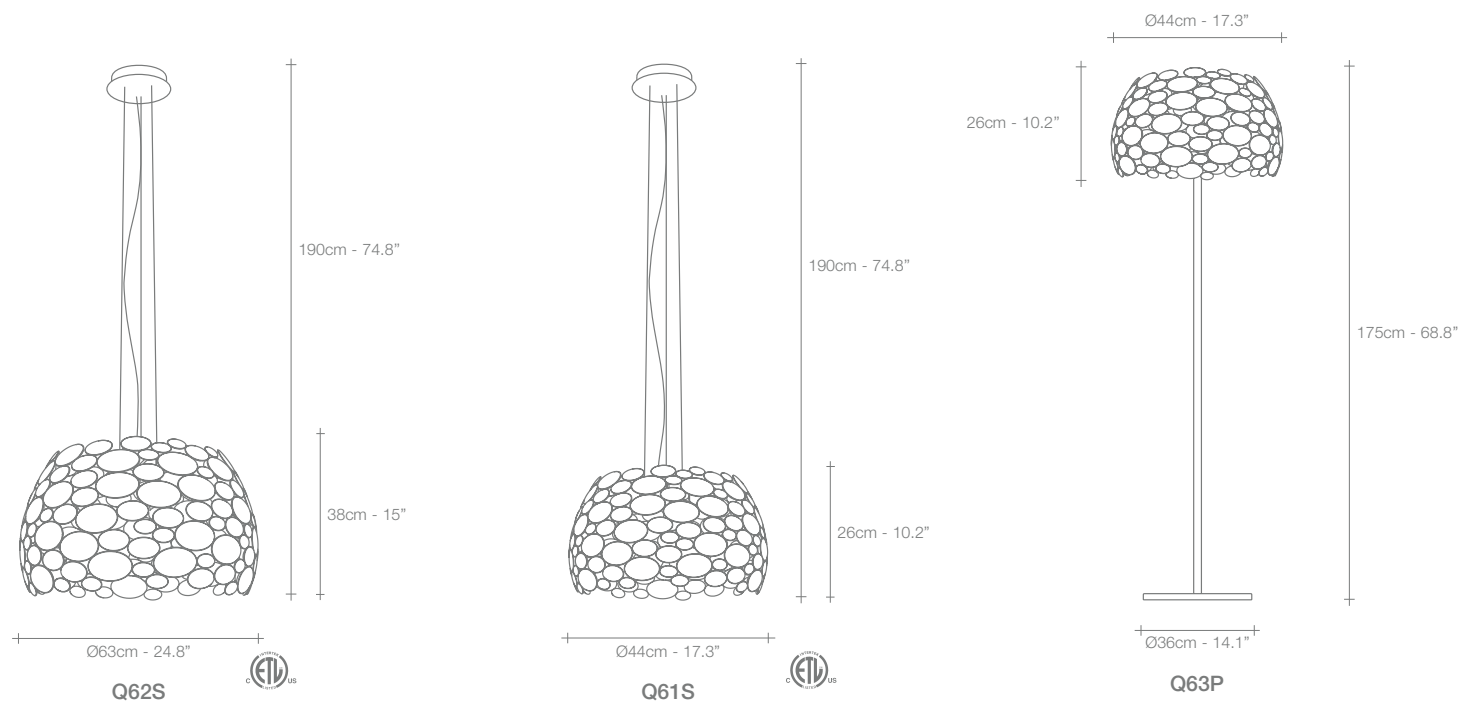

NICKEL



GOLD LEAF

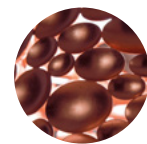

COPPER LEAF

230V / 120V

	Q61S	Q62S	Q63P
LED BOARD	6X4.5W	6X4.5W	6X4.5W
3000 K			
CRI 90			

2700K - CRI 90
LED BOARD
AVAILABLE ON
REQUEST

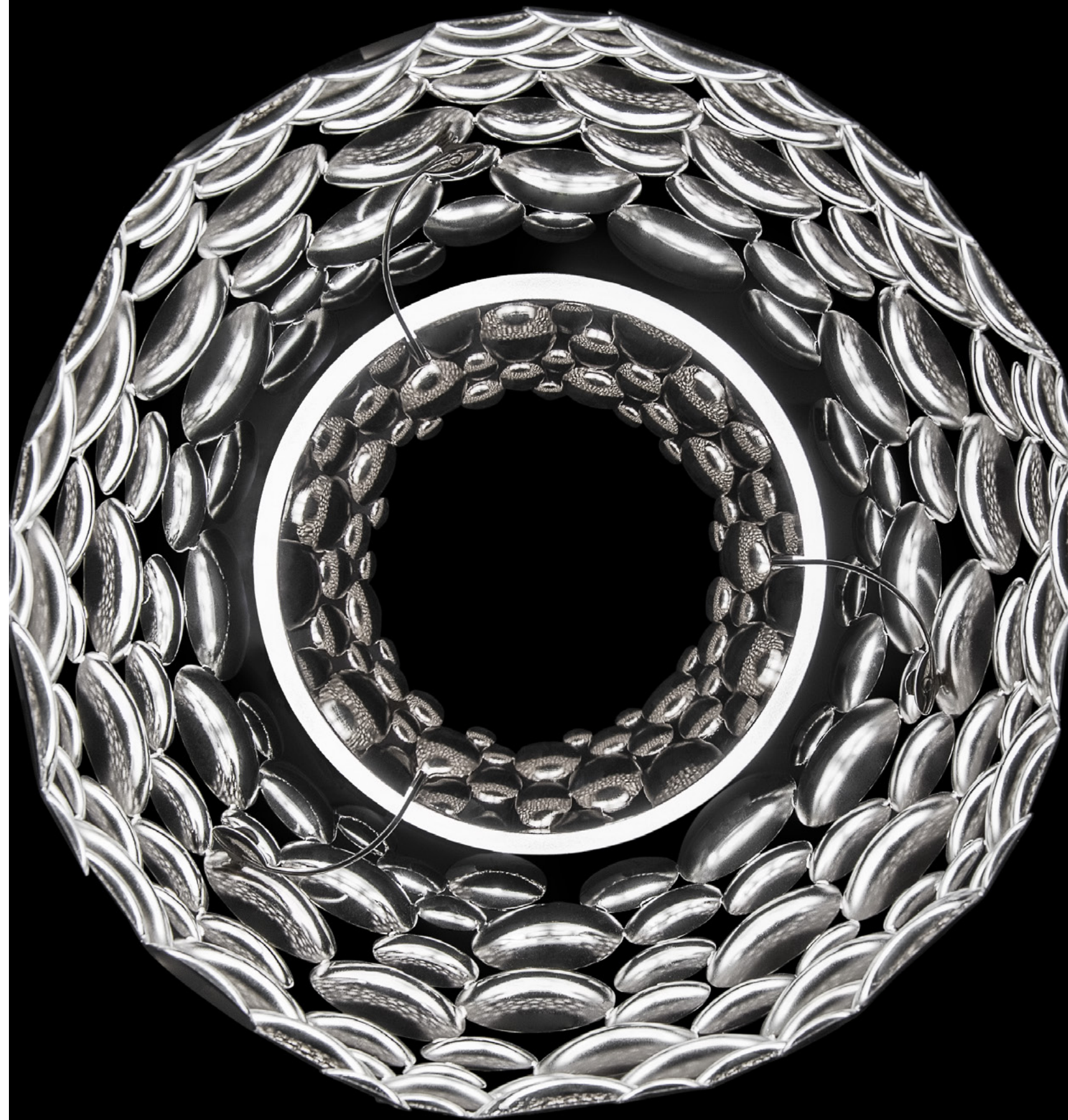

Calle, Perennial *Elegance.*

At Terzani, we spend countless days searching the globe for talented new designers, but sometimes they find us. Such is the case with the young designers Luca Martorano and Mattia Albicini who approached us with the design for Calle, a fantastic a new light we instantly fell in love with. It showcases our skill at crafting crystal to take the material to an exciting, modern place. Luca and Mattia worked with our craftsmen to create a slender inverted flute of crystal that, like the calla lily it mimics, can be grouped into stunning bouquets of light. Design Luca Martorano and Mattia Albicini.









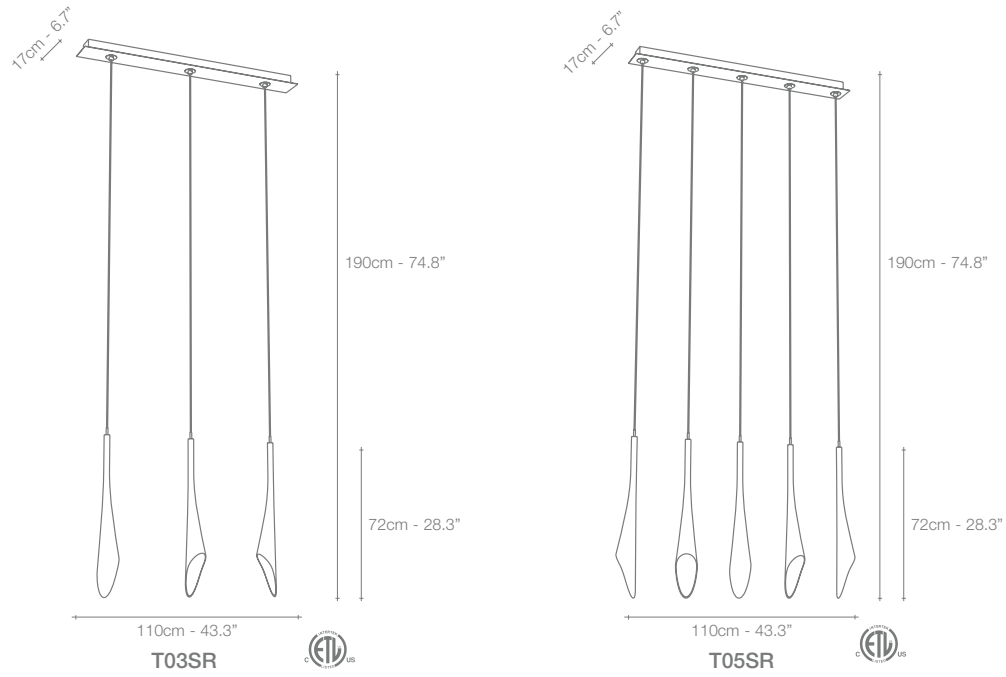
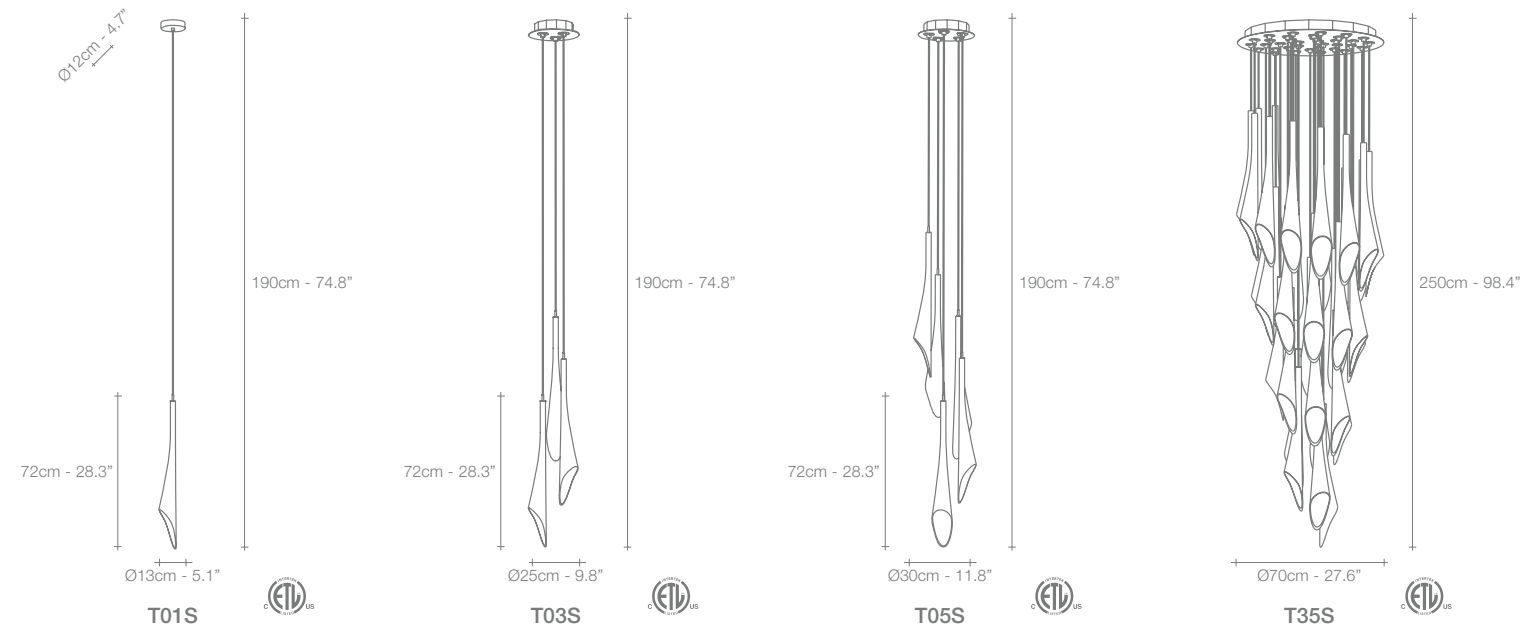

WHITE
CRYSTAL

	T01S	T03S	T05S	T35S	T03SR	T05SR
230V	HALOGEN 12V G4	20W	3X20W	5X20W	35X10W	3X20W
120V	XENON BI-PIN 12V T3 G4	20W	3X20W	5X20W	35X10W	3X20W

CALLE CAN BE
MANUFACTURED TO WORK
WITH BI-PIN LED LIGHT
SOURCE ON REQUEST



Etoile, Twinkling in an *indoor Sky.*

Etoile's intricate network of intersecting nickel lines recalls constellations in a clear night sky. Strategically placed bulbs cast a starry light, twinkling as viewers move around the pendant. Through projecting these complex patterns throughout the room, Etoile casts a heavenly glow in any space. Design Christian Lava.







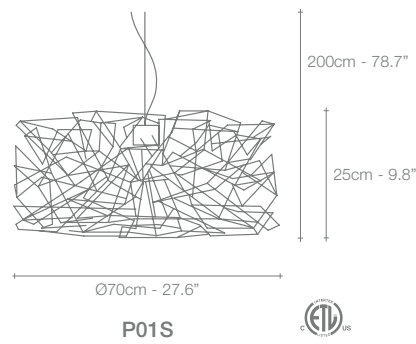

P01S

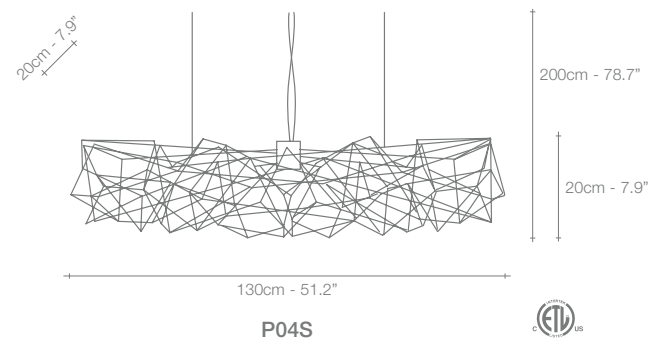

P04S

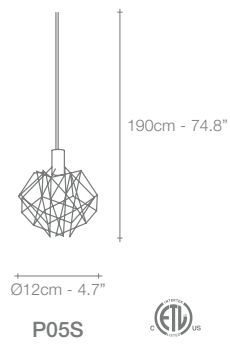

P05S

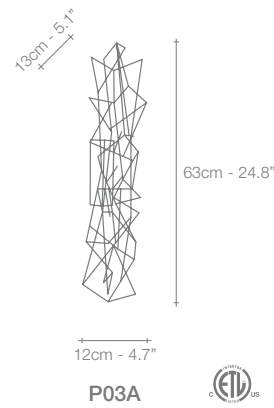

P03A



NICKEL

	P01S	P03A	P04S	P05S
230V	8X10W + HALOGEN 12V G4	6X10W	8X20W	20W
120V	8X10W + XENON BI-PIN 12V T3 G4	6X10W	8X20W	20W

ETOILE CAN BE
MANUFACTURED TO WORK
WITH BI-PIN LED LIGHT
SOURCE ON REQUEST



Frame, Nature's *Imprint.*

Capturing a moment in time, Frame features a metal coral leaf, enclosed inside a borosilicate glass preserving a delicate imprint of nature. Hidden inside is a single bulb which glows from within. Creating a stirring light that projects a dynamic shadow due to the permeable coral. Frame is available in white, red, gold plated or silver plated. Design Terzani Lab.









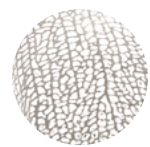
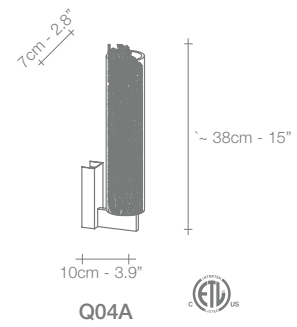
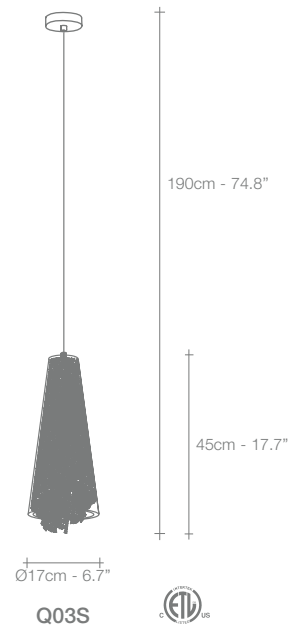
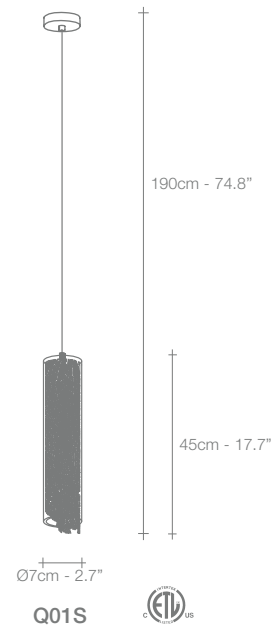
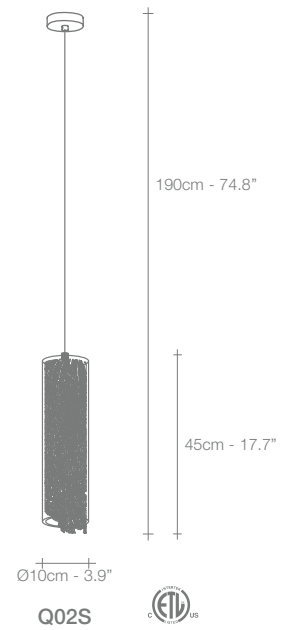

WHITE

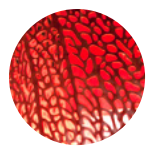



CORAL



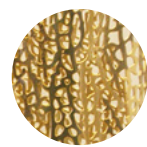

SILVER



GOLD

230V		Q01S	Q02S	Q03S
	HALOGEN ES E14	28W (=40W)	28W (=40W)	42W (=60W)
120V				
	FLAME CA 10 E12	40W	40W	60W

	Q04A
HALOGEN ES G9	33W (=40W)
	
HALOGEN JCD G9	35W

LED LIGHT BULBS MAY BE USED



Orten'zia, Petals of *Light.*

Recalling the natural beauty of a flower, Orten'zia hand-soldered "petals" emanate a unique glow, immersing the entire room in a glimmering light. An organic radiance is created through light and shadow, planting a garden within the room. Available in either nickel or gold plated, the orten'zia's elegant form complements its dramatic light. Design Bruno Rainaldi.















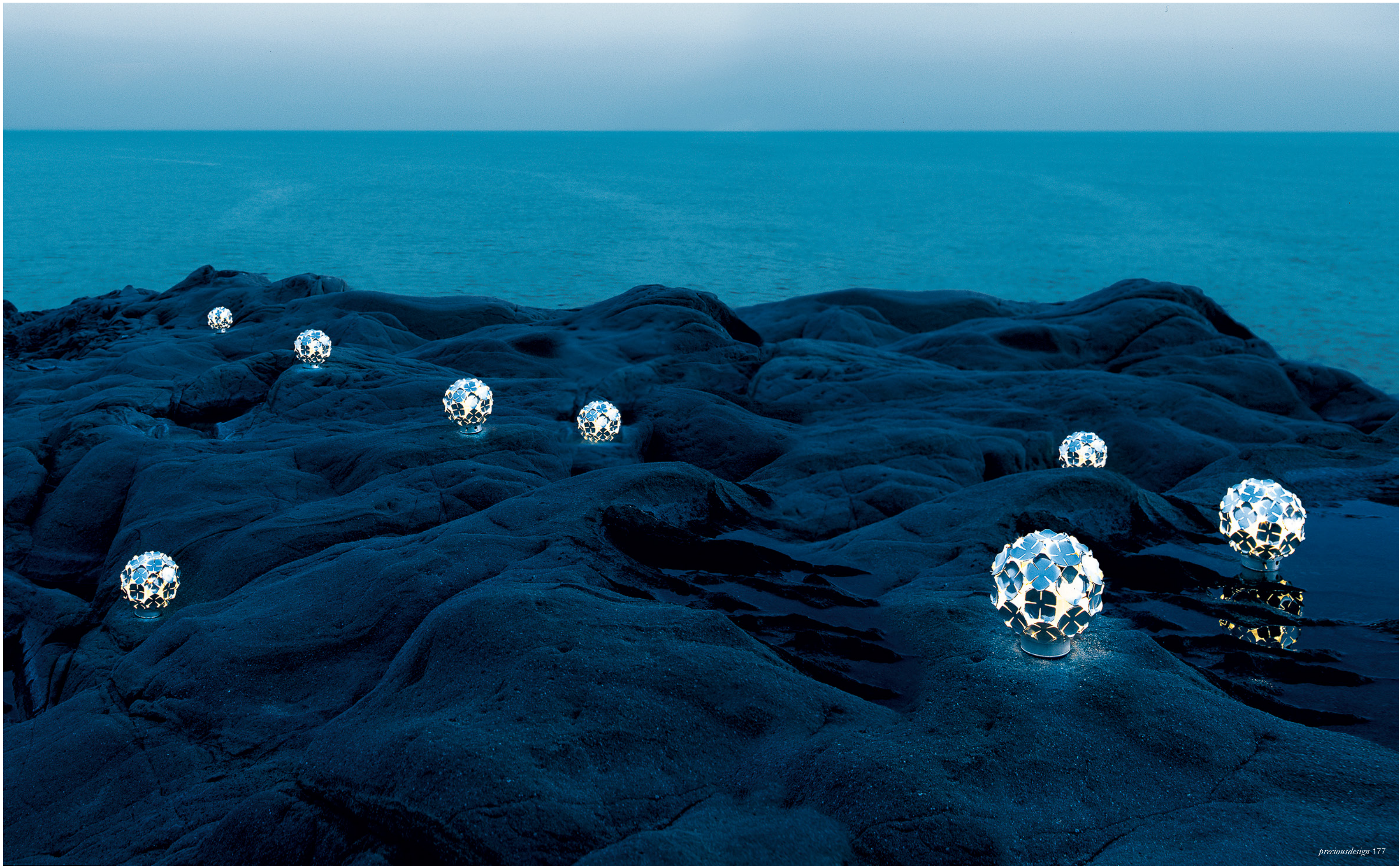

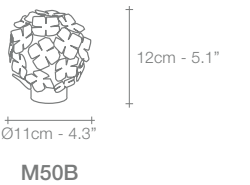
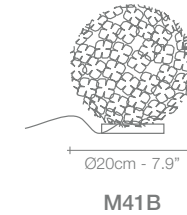
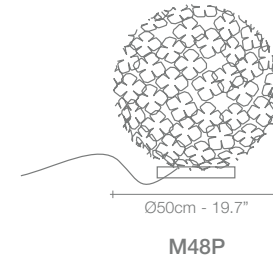
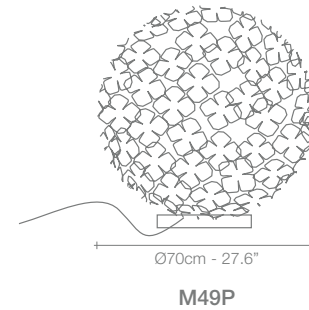
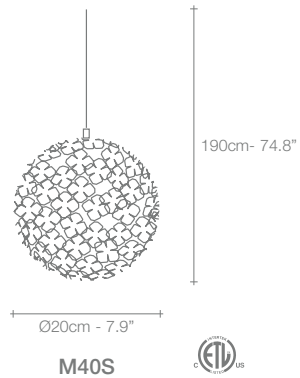
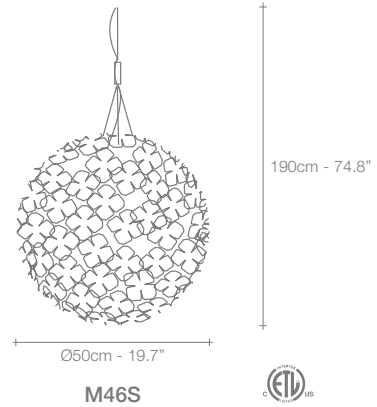
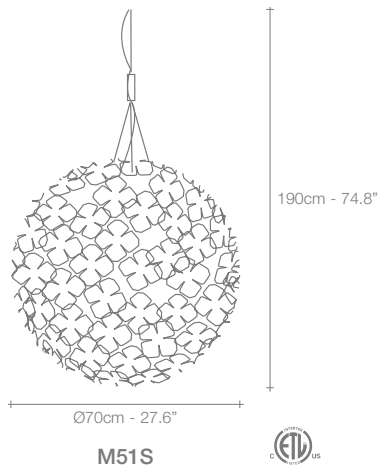

ONLY SILVER
OR GOLD

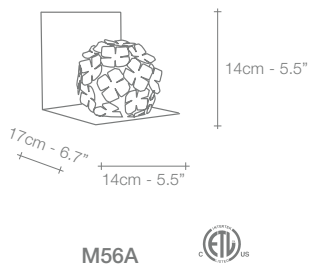
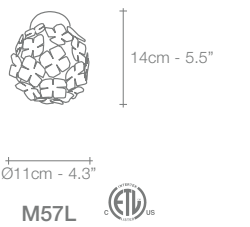
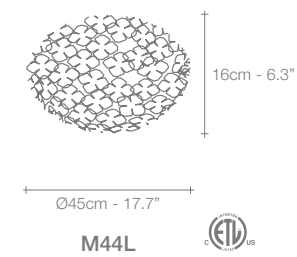
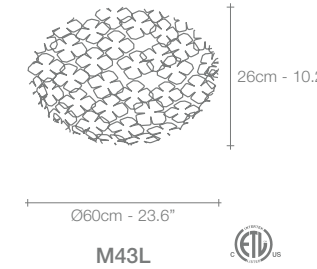
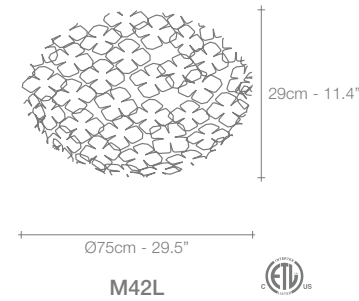
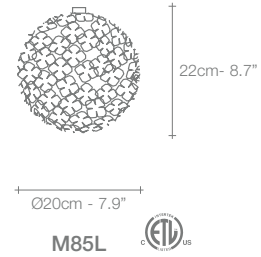
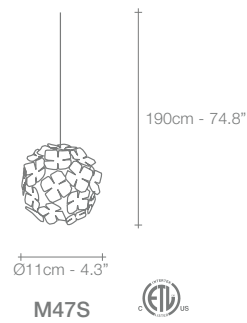
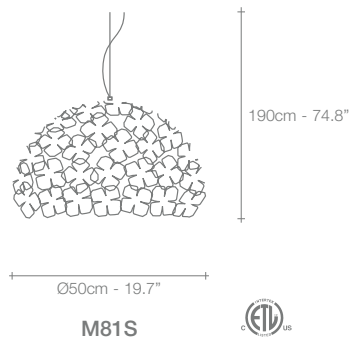

230V		M40S	M41B		M42L	M43L	M46S	M48P	M49P	M51S		M44L		M50B
	HALOGEN ES E14	42W (=60W)	42W (=60W)		HALOGEN ES E27	140W (=200W)	105W (=150W)	140W (=200W)	105W (=150W)	140W (=200W)		140W (=200W)		HALOGEN ES R7S
120V		M40S	M41B		M42L	M43L	M46S	M48P	M49P	M51S		M44L		M50B
	KX-2000 T3 E12	40W	40W		CLEAR STD. TYPE A E26	A23 200W	A23 200W	A23 200W	A21 150W	A23 200W		A23 200W		HALOGEN J-SHORT R7S

230V		M47S	M56A	M57L	M85L		M81S
	HALOGEN ES G9	48W (=60W)	48W (=60W)	33W (=40W)	33W (=40W)		COMPACT FLUO. E27
120V		M47S	M56A	M57L	M85L		M81S
	HALOGEN JCD G9	50W	50W	50W	35W		GLOBE G40 E26

G.r.a, gyrating Romantic *rings of Light.*

This clean, precise form is the result of hours of labor by our artisans, who meticulously weld each ring together. G.r.a. is a delicate, refined pendant whose intricate shape belies its romantic glow. Available as an oval or a sphere, and finished in nickel or gold, G.r.a. serves as an elegant, unobtrusive complement to any room. Design Bruno Rainaldi.







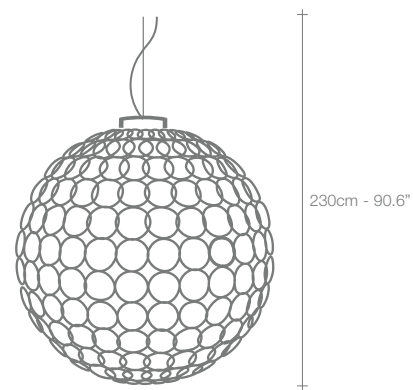

Ø90cm - 35.4"

230cm - 90.6"

N40S or N40SL

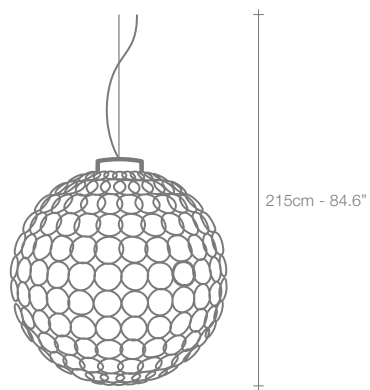

Ø70cm - 27.6"

215cm - 84.6"

N42S or N42SL

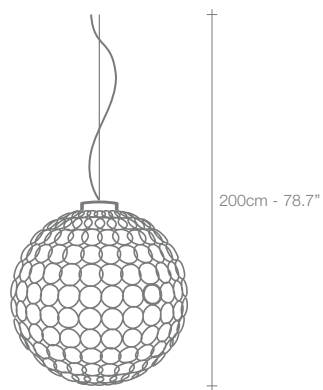

Ø54cm - 21.3"

200cm - 78.7"

N43S or N43SL

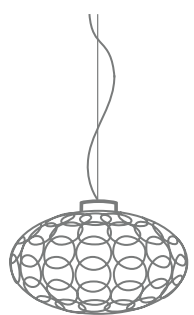

Ø50cm - 19.7"

170cm - 66.9"

23cm - 9.1"

N41S or N41SL



NICKEL

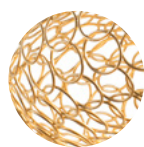

GOLD LEAF

		N40S	N41S	N42S	N43S	or	N40SL	N41SL	N42SL	N43SL	
230V	HALOGEN HPAR R 111 GZ10	100W	100W	100W	100W						
							COB LED 3000 K CRI 90	22W	22W	22W	22W
120V	HALOGEN R 111 GU10	75W	75W	75W	75W						

2700K - CRI 90 COB LED
AVAILABLE ON REQUEST

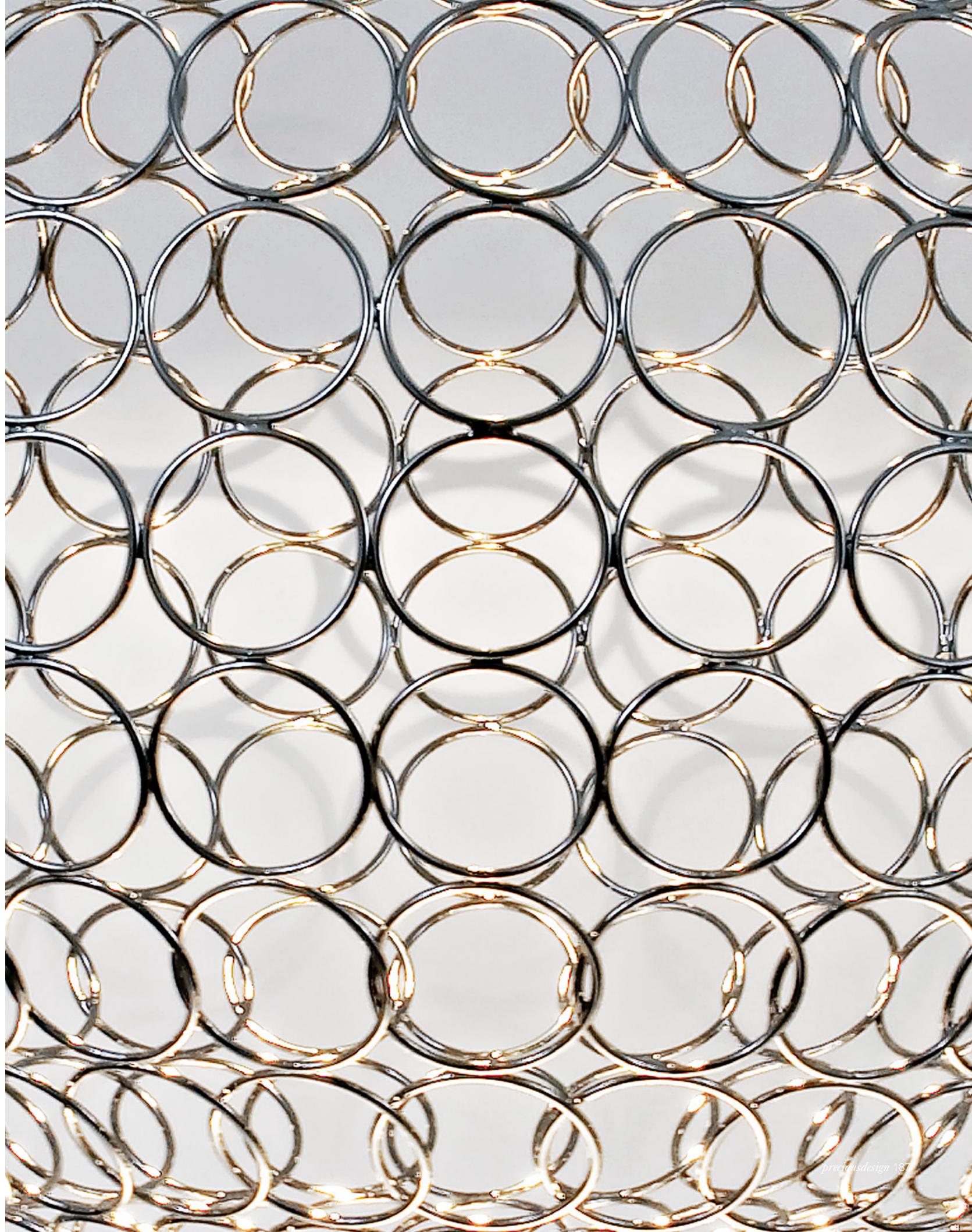

Core, Eruption *of Light.*

Core is reminiscent of the natural energy at the heart of our world. Like bright lava seeping through the earth's crust, vibrant spheres of faceted crystal break through the iron surface of this pendant. Forcing light to pass through this metal structure results in a powerful, vibrant exchange of forces light and shadow erupt across the room, as the LED light pours through, as the light itself emits an organic radiance. Design Christian Lava.







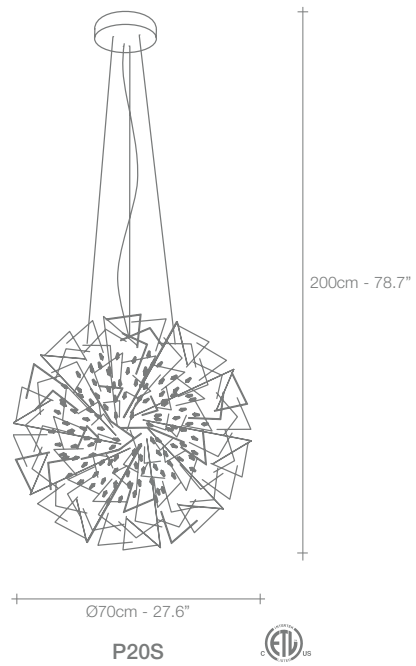

P20S

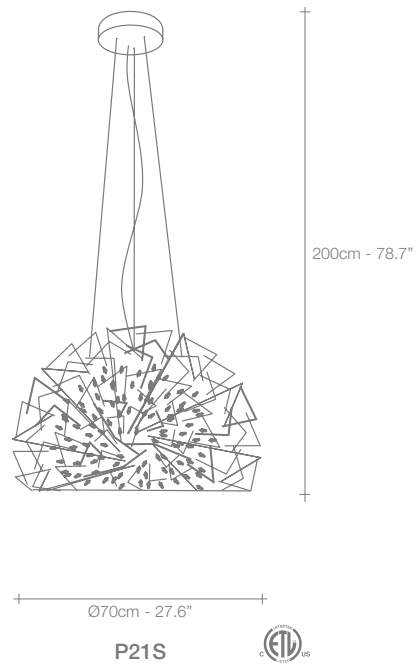

P21S

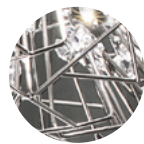

NICKEL CLEAR



BLACK NICKEL CLEAR

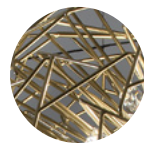

GOLD

230V / 120V



	P20S	P21S
COB LED		
3000 K		
CRI 90	22W	22W

2700K - CRI 90
COB LED
AVAILABLE ON
REQUEST



Angel Falls, Cast down *Earth.*

For his first work for Terzani, Nigel Coates, well known for his unorthodox approach to design, has created an engaging, unique light. Customizable groups of crystal "angels" are illuminated by halogen lamps. What caused these angels to fall from the heavens? It's up to the viewers to decide. Either way, angel falls is sure to garner attention, and generate conversation, in any setting. Design Nigel Coates.





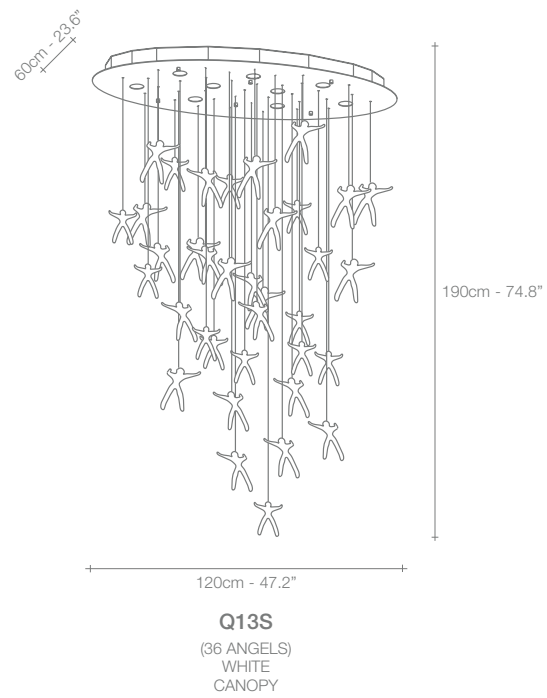
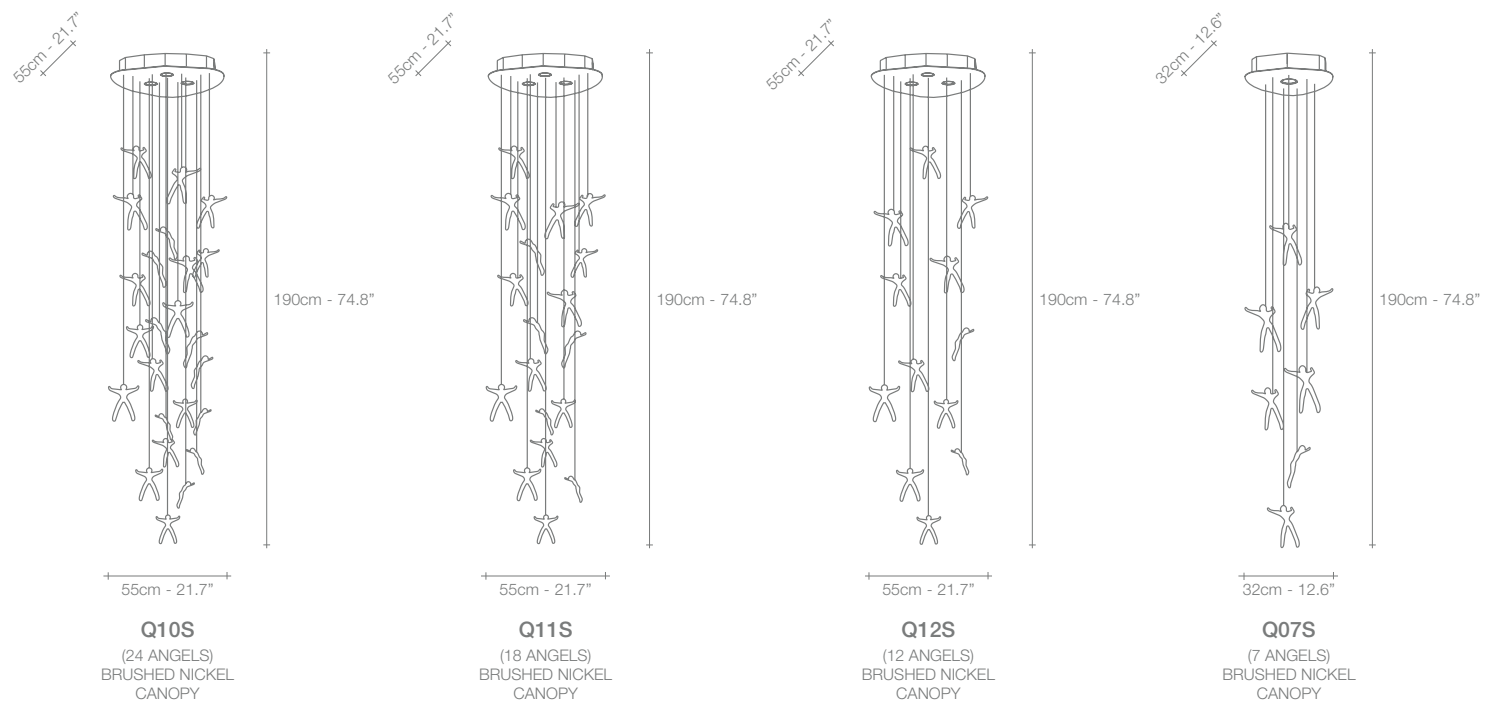

CRYSTAL

	Q07S	Q10S	Q11S	Q12S	Q13S	
230V	HALOGEN GU10	50W	3X50W	3X50W	3X50W	9X35W
120V	HALOGEN MR16 GU10	50W	3X50W	3X50W	3X50W	9X35W

LED LIGHT BULBS MAY BE USED





Shar Pei, Lighthearted *Luxury.*

Shar Pei, employs sheaths of “wrinkled” crystal that take their cues from shar pei puppies. The “cute factor” is replaced by a stunning and elegant display created by the projection of light through the undulating crystal. These lights can also be grouped together to create a “pack” of lights. Design Luca Martorano + Mattia Albicini.

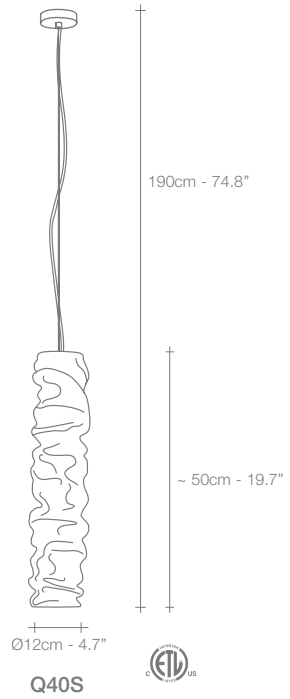



230V		Q40S
	HALOGEN 12V GY 6.35	35W (=40W)
120V		
	XENON BI-PIN 12V T3 GY 6.35	35W



Iceberg, Pure *Light.*

Inspired by the natural beauty of ice crystals, this new suspension light creates a spectacular, luminous piece through the use of over 3,600 plexyglass tubes. Similar to light refracting through water, the illumination created by Iceberg is both brilliant and natural, meticulously handcrafted, each light is a unique sculpture; sparkling, multifaceted and powerful. Design Dodo Arslan.



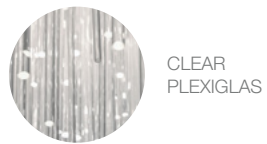
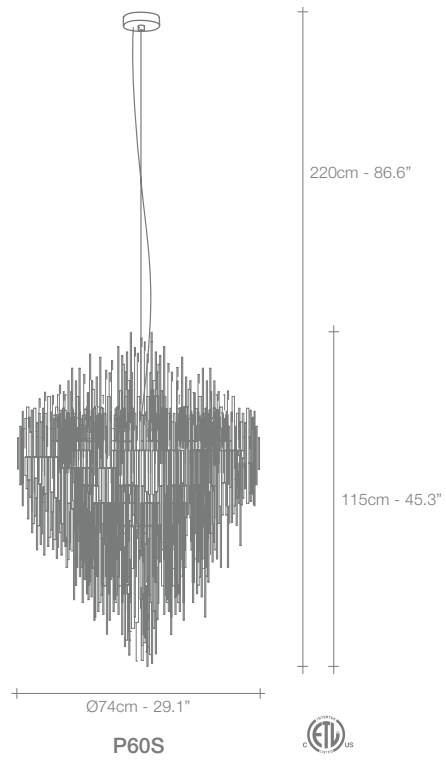

- 230V**
- COMPACT FLUO. E14 + COMPACT FLUO. E27 6X14W E14 + 23W E27
- 120V**
- COMPACT FLUO. E12 + COMPACT FLUO. E26 6X12W E12 + 23W E26



Glamour, Modern *Seduction.*

Glamour's randomly interspersed rings imbue this design with a seductiveness rarely applied to geometric shapes. Whether finished in gold, nickel or white, the diffused light emanating behind Glamour's rings bathes the surrounding area in a soft, sensuous glow. Available as a wall sconce, table lamp or pendant, glamour can provide subtle accents or act as the focal point of a room. Design Dodo Arslan.



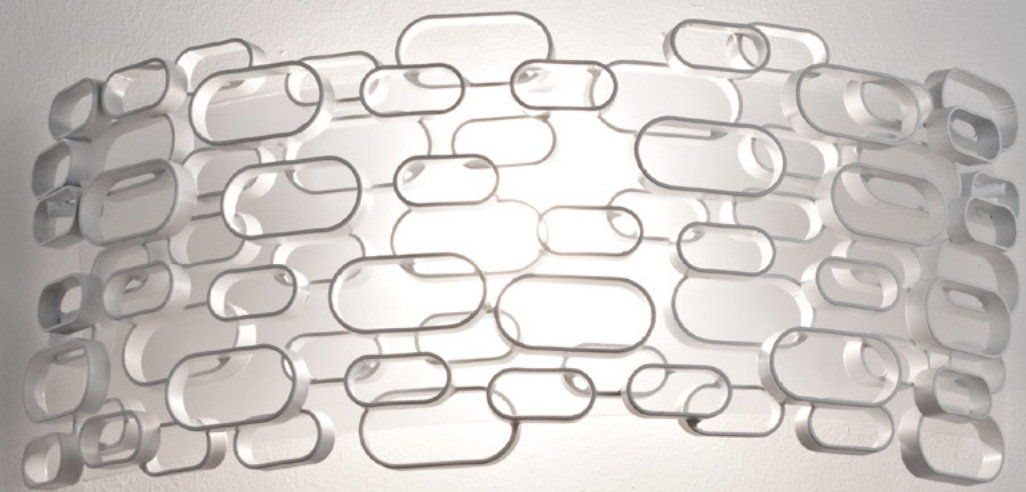

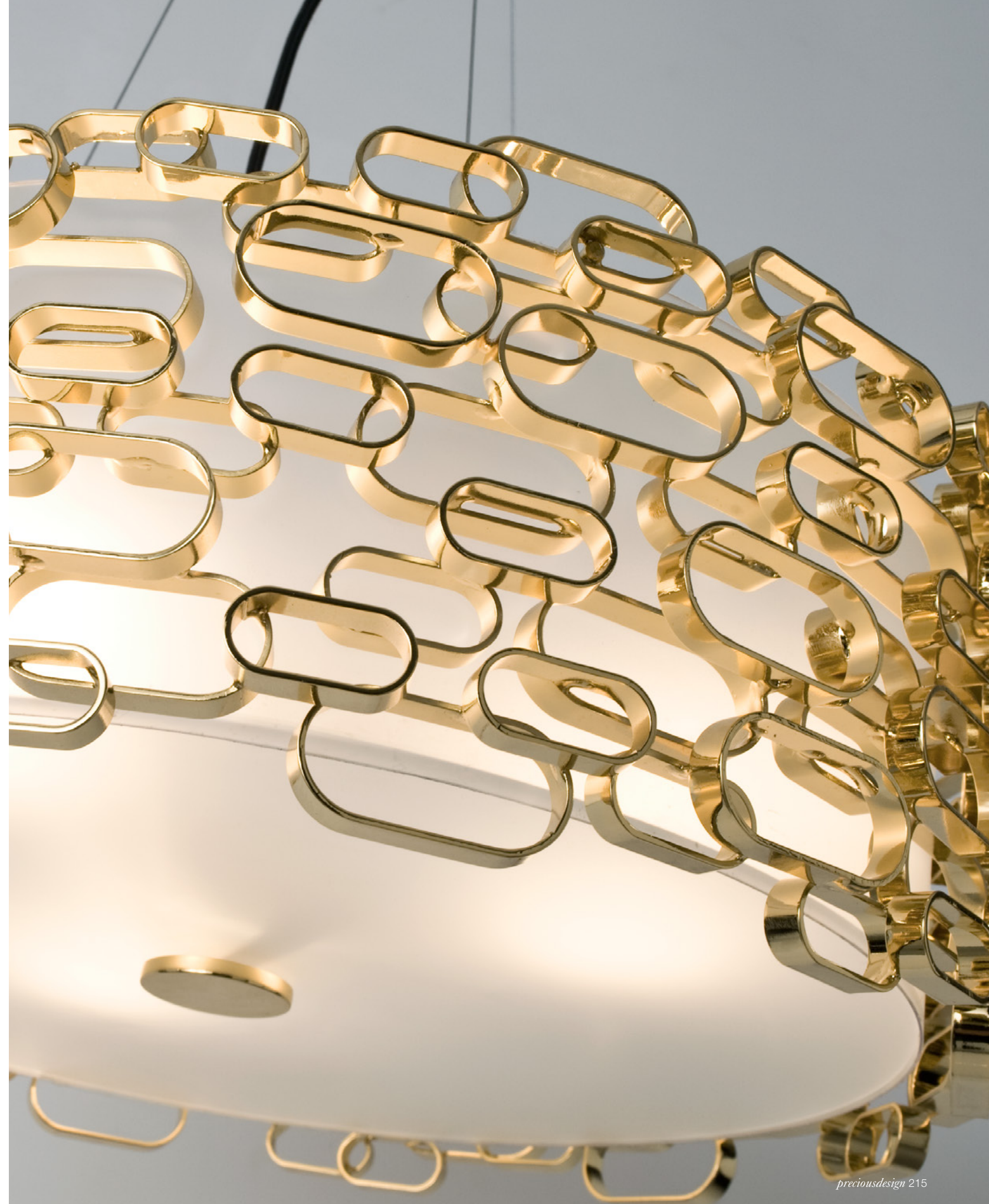

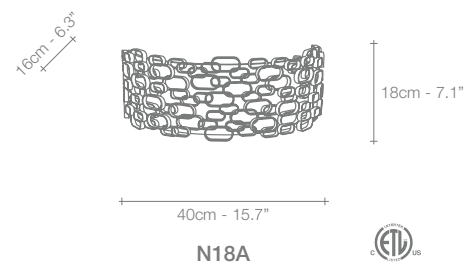
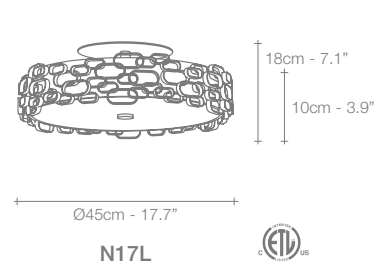
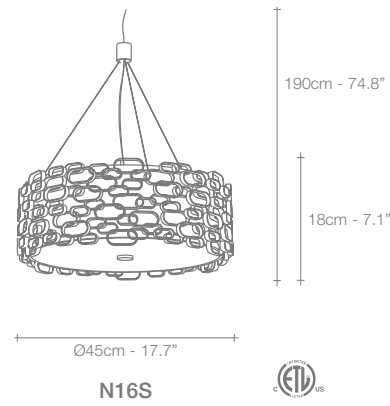

230V		N16S	N17L	N18A
	HALOGEN ES E14	3X28W (=3X40W)	3X28W (=3X40W)	HALOGEN ES R7S 48W (=60W)
120V				
	CLEAR GLOBE G12 E12	3X40W	3X40W	HALOGEN J-SHORT R7S 75W



Magdalena, Cutting edge *Beauty.*

Reaching inside traditional forms, Magdalena's laser-cut, horizontal openings allow for its light to expand its range to the entire room. Creating an alluring pattern of light and shadow, Magdalena highlights the shape of the room itself. This unique exchange creates a pendant that impacts every space, regardless of size. Design Bruno Rainaldi.





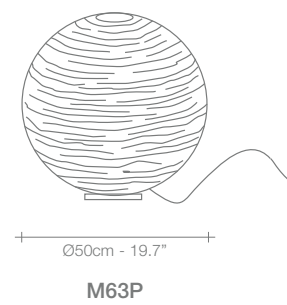
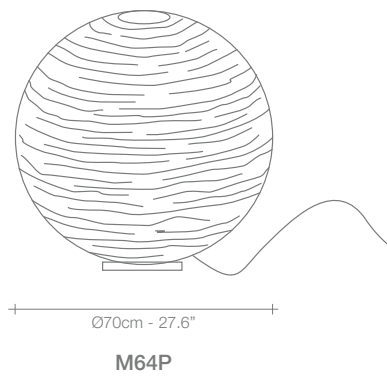
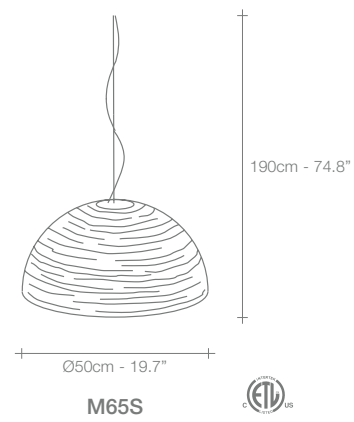
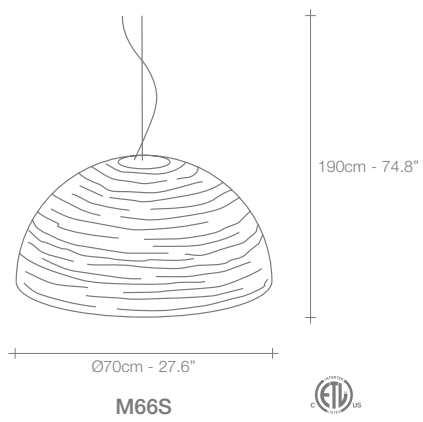
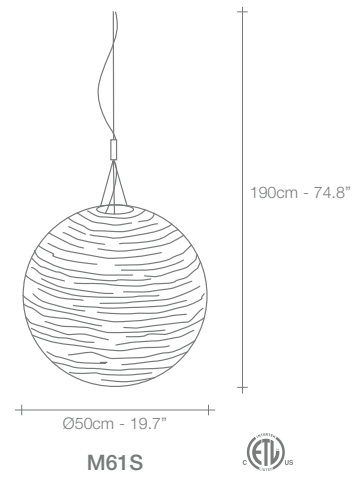
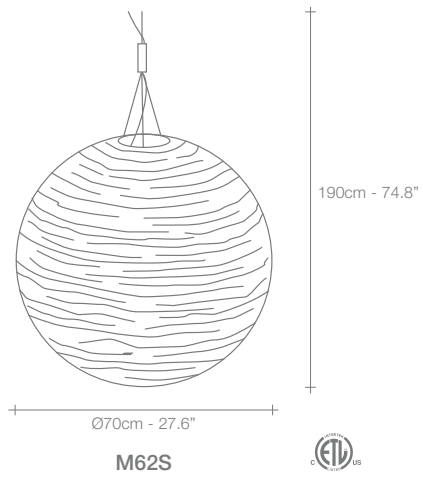

	M61S	M62S	M63P	M64P	M65S	M66S
230V	HALOGEN ES E27	140W (=200W)	140W (=200W)	105W (=150W)	140W (=200W)	COMPACT FLUO. E27 23W
120V	CLEAR STD. A23 E26	200W	200W	200W	200W	GLOBE G40 E26 150W



Bond, brands of *Racing Light.*

Bond's bands of light expose a deceptively luxurious interior. Under the glass exterior, lays a core of gold leaf that creates a deep, complex radiance. The overall glow is intensified by incisions that emit focused, dramatic lines of light. Extremely versatile, Bond is available in three sizes; as either a pendant or a table/floor light; and with a black or white exterior. Whether alone or grouped together, Bond's light creates a dynamic atmosphere. Design Bruno Rainaldi.



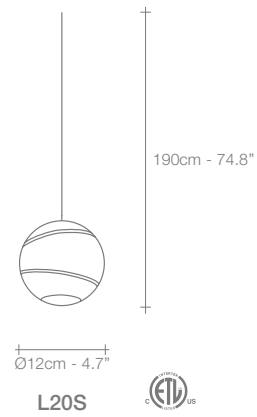
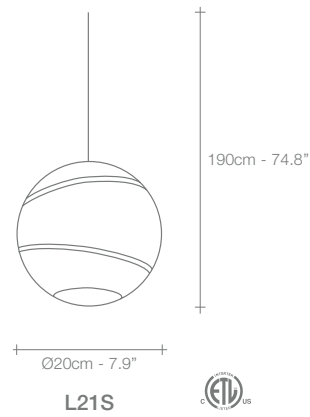



CLEAR GLASS
WHITE WITH
GOLD LEAF



CLEAR GLASS
BLACK WITH
GOLD LEAF

		L20S		L21S
230V	HALOGEN ES G9	20W (=25W)	HALOGEN ES E14	42W (=60W)
120V	HALOGEN JCD G9	20W	HALOGEN JCD G9	35W



Sea Urchin, Dress your *Light.*

Pushing the boundaries of design and artistry; drawing from the haute couture designer's unique universe, sea urchin features over 1500, translucent crystal "pins" seemingly suspended around the bulb, casting a dynamic shadow around the room. The perfect accessory for your well-curated home, sea urchin is available in different finishes in both round and oblong versions. Design Maurizio Galante.







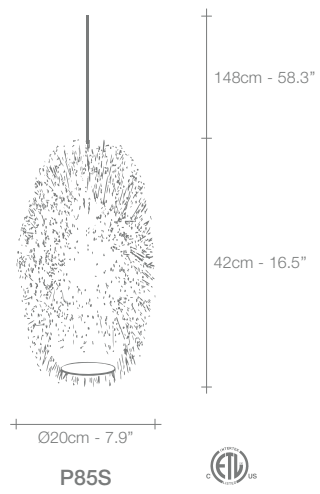
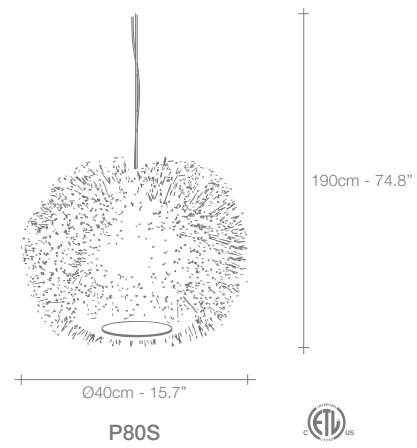
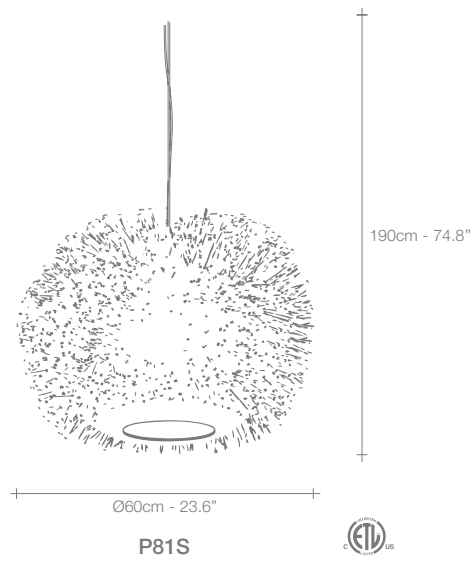

NICKEL SILVER WHITE

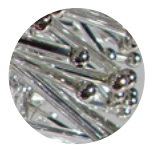

NICKEL SILVER SILVER



NICKEL SILVER SWAROVSKI

	P80S	P81S	P85S
230V	HALOGEN ES E27	70W (=100W)	70W (=100W)
120V	HALOGEN ECO A19 E26	72W (=100W)	72W (=100W)
			HALOGEN ES E14
			42W (=60W)
			KX-2000 T3 E12
			40W

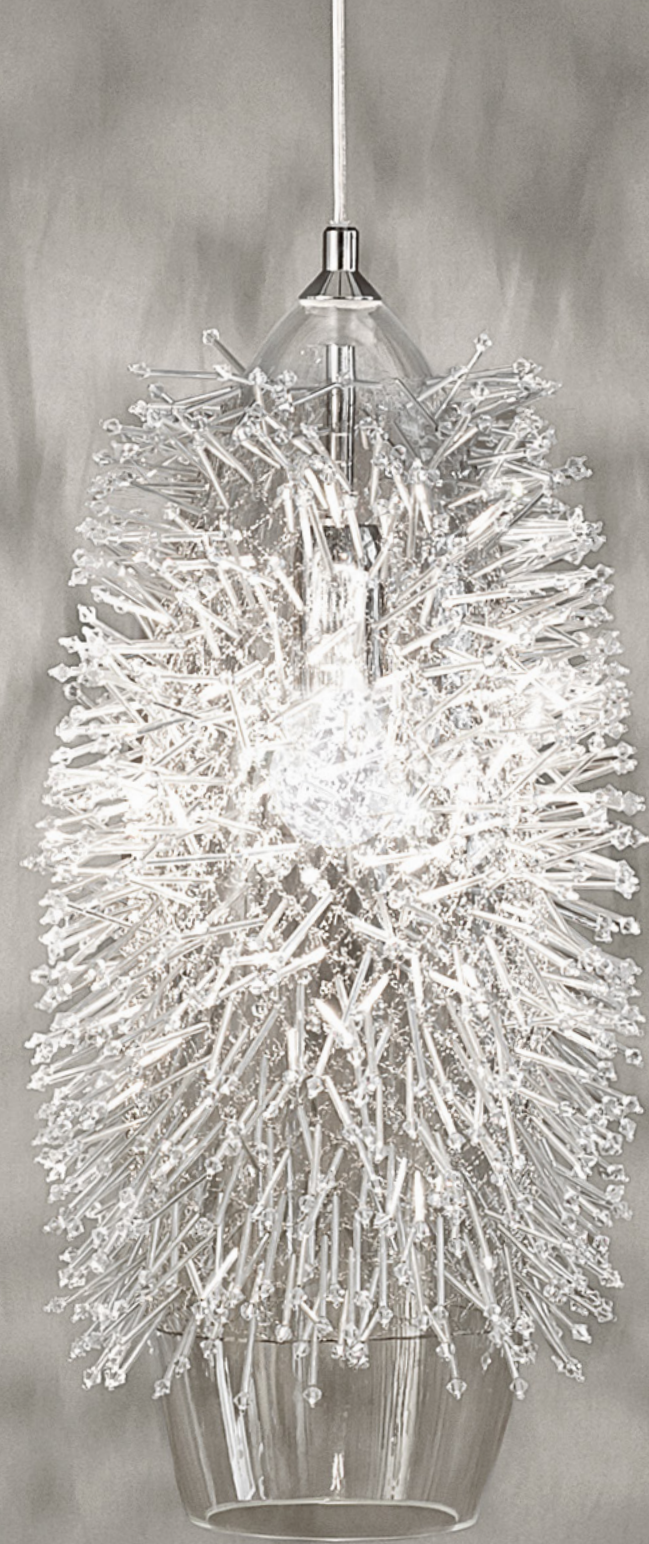

Tresor, a Wealth *of Light.*

An impeccable addition to any space, Tresor's hand-made design and precious metal "coins" create scintillating halos of light. Recalling discovered treasure, the layers of gold or silver leaf create a rich, luxurious light. Available in a range of sizes, including wall sconces and pendants, Tresor has an elegance that is truly priceless. Design Jean François Crochet.

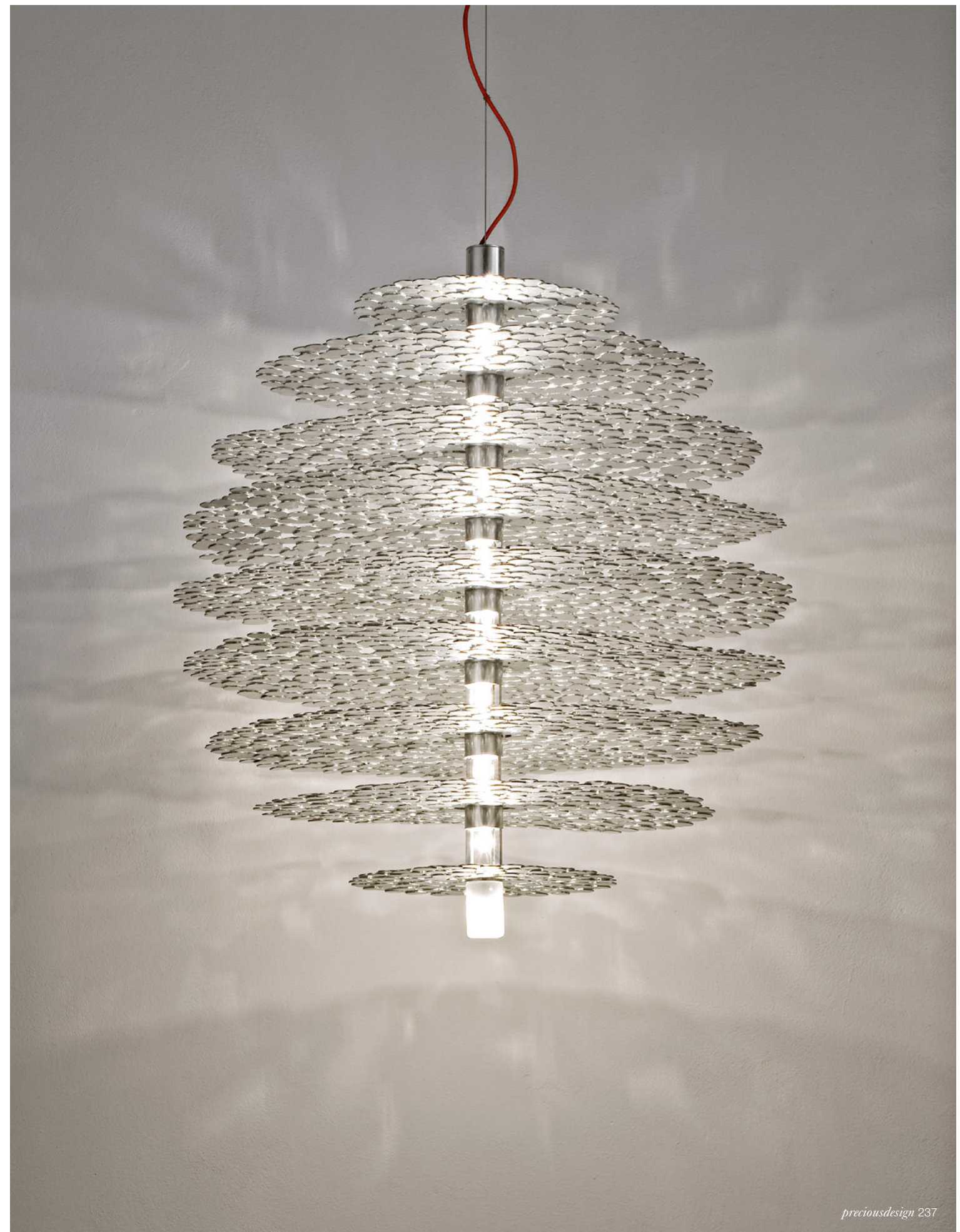



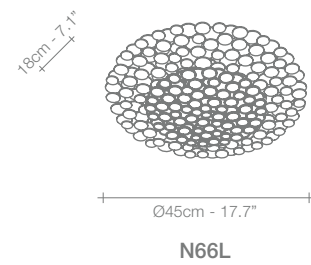
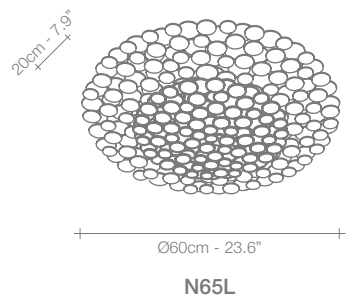
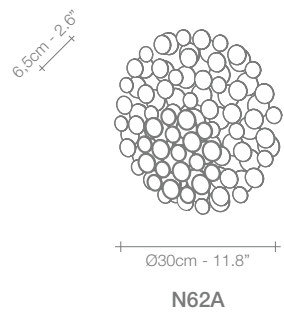
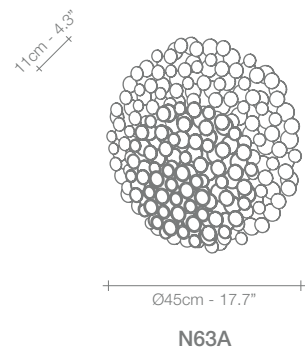
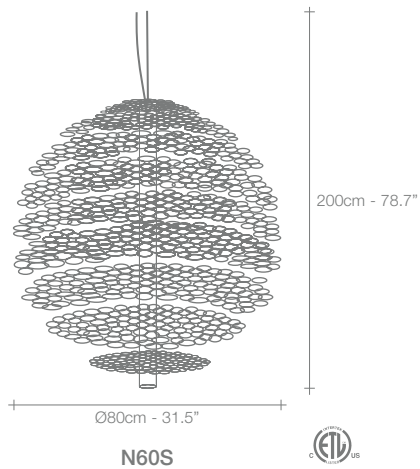

GOLD LEAF



SILVER LEAF

	N60S	N62A	N63A	N65L	N66L
230V	HALOGEN ES G9	9X33W (=9X40W)	48W (=60W)	2X48W (=2X60W)	6X33W (=6X40W)
120V	HALOGEN JCD G9	9X35W	50W	2X50W	6X35W

LED LIGHT BULBS MAY BE USED



Hook, an Alluring *Design.*

Hook, comprised of a series of arched arms, creates an enticing light that draws people towards it. Bathing the room in a soft glow, viewers are easily captured by Hook's inviting elegance. Its clean design lends well in a variety of settings, casting a light that is equally suitable in commercial or residential environments. Design Jean François Crochet.



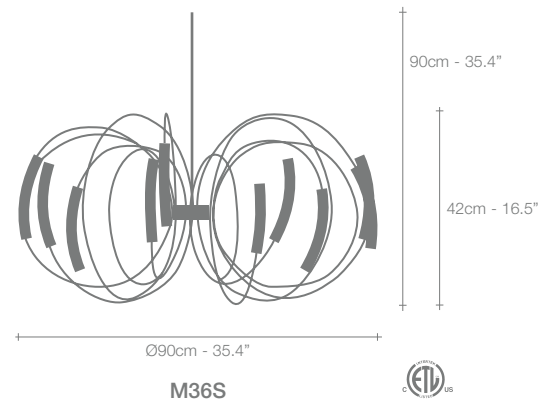

		M36S	HOOK CAN BE MANUFACTURED TO WORK WITH BI-PIN LED LIGHT SOURCE ON REQUEST
230V	HALOGEN 12V G4	12X14W (=12X20W)	
120V	XENON BI-PIN 12V T3 G4	12X20W	



Zig-Zag, Easy *Sophistication.*

Either alone or a group, Zig-Zag is a truly unique way to add light to any space. Intended to lean nonchalantly against a wall, the soft glow from the notched, Zig-Zag openings creates a comfortable ambience while adding a distinctly progressive design element. Zig-Zag complements rooms with high ceilings while opening up smaller spaces. Design Jean François Crochet.



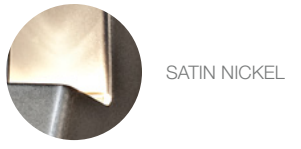
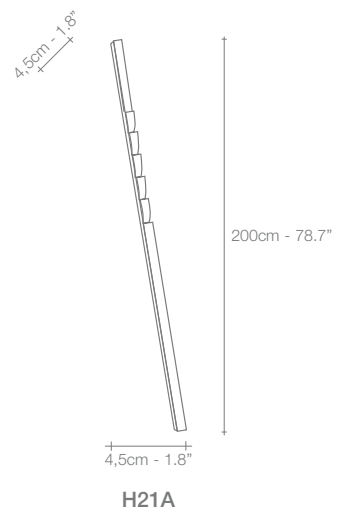
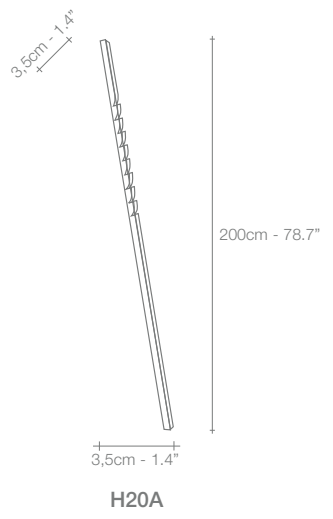

	H20A	H21A
230V	HALOGEN 12V G4	9X5W 6X10W
120V	XENON BI-PIN 12V T3 G4	9X5W 6X10W

ZIG-ZAG CAN BE
MANUFACTURED TO WORK
WITH BI-PIN LED LIGHT
SOURCE ON REQUEST





Hugo, a Welcome *Guest.*

Some designs are strong enough to stand alone. These are the pieces that transform spaces and inspire viewers. Hugo, a unique sculpture created by Terzani's master craftsmen, is composed of hand-forged metal stems, encasing a single light. With a graceful, delicate form, Hugo is a welcome guest in any space, intriguing and powerful. Design Jean François Crochet.

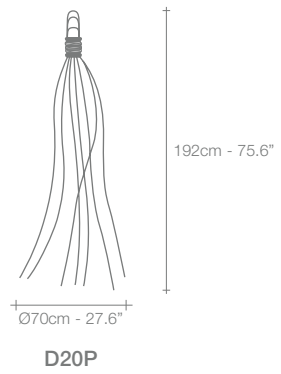



- | | | |
|------|---|-------------------------|
| 230V | 
HALOGEN
ES E27 | D20P
105W
(=150W) |
| 120V | 
HALOGEN
ECO A19 E26 | 72W
(=100W) |



Wabi, Understated *Elegance.*

Influenced by the rustic simplicity of the mulberry tree, Nicolas Terzani set out to create a piece that delivered the same quiet, harmonious elegance. Thus, wabi, available in white, gold-plated or silver-plated finish, which recalls the serenity and balance of its natural inspiration. The texture of wabi harnesses the anomalies of a cortex, resulting in a unique and classic light. Design Nicolas Terzani.



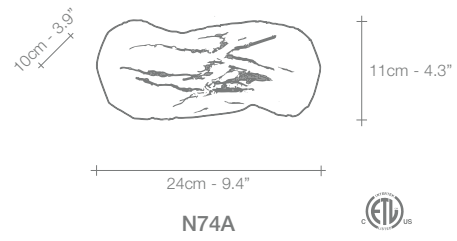

NICKEL



GOLD

N74A



230V HALOGEN ES R7S 48W (=60W)



120V HALOGEN J-SHORT R7S 75W





Terzani has a tradition deeply rooted in Italian craftsmanship. From shaping precious metals to painstakingly constructing every piece, our master craftsmen give attention to every design, resulting in unparalleled quality and a distinct aesthetic.

Art and *Crafts*





TERZANI
LA LUCE PENSATA

All products in the Terzani collections are inspired by a return to noble artisan traditions. Every object is carefully created using craft techniques and for this reason certain details may vary from product to product. These variations are not imperfections but characteristic peculiarities of the production process. Terzani reserves the right to modify its products in order to improve its features. The reproduction on paper of products may result in a misrepresentation of some colors. Measurements are in cm and inches. For updated technical data please refer to our current price list or our website. For updates on etl  please visit our website or call our customer service. Etl  certification may be available on request when not listed. All products are  certified.

Terzani srl

Via Castelpulci Int.9
50018 Firenze Italy
Ph +39 055 722021
F +39 055 7311161
info@terzani.com

Terzani Usa, Inc.

2501 SW 56th Ave
Pembroke Park FL 33023
Ph 954 438 7779
F 954 438 7566
Toll free1 (866) 380 5412
info@terzaniusa.com

Creative Direction Terzani
Art Direction Camilla Cordella
Photos Leonardo Beglieri
Photo (pages 28/29) Riccardo Urnato
Digital imaging Fulvio Gallotti
Eu (Italy) 2017

terzani.com

© terzani 2017



